

JVC

SERVICE MANUAL

CASSETTE RECEIVER

KS-FX950R

Area Suffix

E ---- Continental Europe

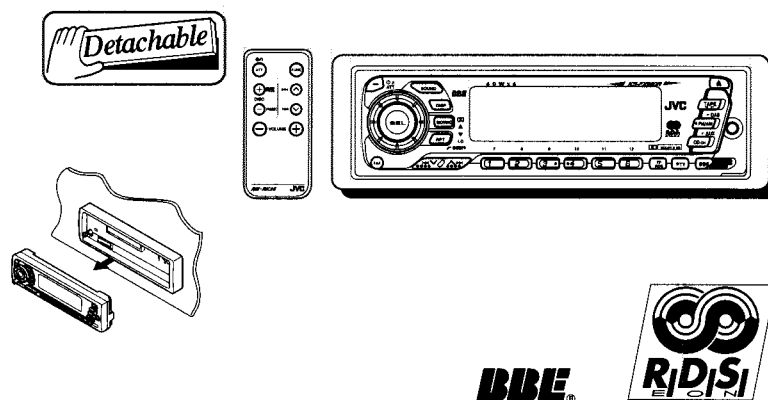

Contents

Safety precaution	1-2	Description of major ICs	2-11
Instructions	1-3~18	Block diagram	2-26
Disassembly method.....	2-1	Standard schematic diagrams	2-27
Adjustment method	2-8	Printed circuit boards	2-30~32
		Parts list	3-1~15

Safety precaution

 **CAUTION** Burrs formed during molding may be left over on some parts of the chassis. Therefore, pay attention to such burrs in the case of performing repair of this system.

Instructions

JVC

CASSETTE RECEIVER
CASSETTEN-RECEIVER
RADIOCASSETTE
RADIO/CASSETTESPELER

KS-FX950R

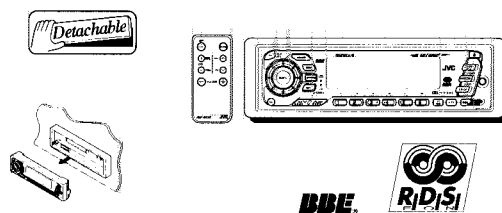

For installation and connections, refer to the separate manual.
Angaben zu Einbau und Verkabelung entnehmen Sie bitte der gesonderten Anleitung.
Pour l'installation et les raccordements, se référer au manuel séparé.
Zie de afzonderlijke handleiding voor details aangaande het installeren en verbinden van het toestel.

INSTRUCTIONS
BEDIENUNGSANLEITUNG
MANUEL D'INSTRUCTIONS
GEBRUIKSAANWIJZING

ENGLISH
DEUTSCH
FRANÇAIS
NEDERLANDS

Having TROUBLE with operation?

Please reset your unit
Refer to page of How to reset your unit

Haben Sie PROBLEME mit dem Betrieb?

Bitte setzen Sie Ihr Gerät zurück
Siehe Seite Zurücksetzen des Geräts

Vous avez des PROBLÈMES de fonctionnement?

Réinitialisez votre appareil
Référez-vous à la page intitulée Comment réinitialiser votre appareil

Hebt u PROBLEMEN met de bediening?

Stel het apparaat terug
Zie de pagina met de paragraaf Het apparaat terugstellen

JVC

VICTOR COMPANY OF JAPAN, LIMITED





EN, GE, FR, NL

1299MNMMDWJES

FSUN3124-311
(E)

Thank you for purchasing a JVC product. Please read all instructions carefully before operation, to ensure your complete understanding and to obtain the best possible performance from the unit.







CONTENTS

BASIC OPERATIONS	4	
RADIO BASIC OPERATIONS	5	
Listening to the radio	5	
Storing stations in memory	6	
FM station automatic preset: SSM	6	
Manual preset	7	
Tuning into a preset station	8	
RDS OPERATIONS	9	
What you can do with RDS EON	9	
Tracing the same programme automatically (Network-Tracking Reception)	9	
Using Standby Reception	11	
Selecting Your Favorite Programme for PTY Standby Reception	12	
Searching Your Favorite Programme	12	
Other convenient RDS functions and adjustments	15	
Automatic selection of the station when using the number buttons	15	
Changing the display mode while listening to an FM station	15	
Setting the TA volume level	15	
Automatic clock adjustment	16	
TAPE OPERATIONS	17	
Listening to a tape	17	
Automatic tape type detection	18	
Prohibiting cassette ejection	18	
Finding the beginning of a tune	19	
Other convenient tape functions	20	
Turning on/off Tuner Call Play	20	
Skipping the blank portions on the tape	20	
Playing the current tune repeatedly	20	
SOUND ADJUSTMENTS	21	
Turning on/off the BBE function	21	
Selecting preset sound modes	22	
Adjusting the sound	23	
Storing your own sound adjustments	24	

BEFORE USE

- * For safety...
- Do not raise the volume level too much, as this will block outside sounds, making driving dangerous.
- Stop the car before performing any complicated operations.

* Temperature inside the car...
If you have parked the car for a long time in hot or cold weather, wait until the temperature in the car becomes normal before operating the unit.

OTHER MAIN FUNCTIONS	25	
Setting the clock	25	
Changing the general settings (PSM)	26	
Selecting the clock display	28	
Selecting the CD Text information display	28	
Selecting the level display	28	
Selecting the dimmer mode	29	
Controlling the volume automatically (Audio Cruise)	29	
Selecting the telephone muting	31	
Turning on/off the key-touch tone	31	
Turning on/off the power amplifier switch	31	
Selecting the scroll mode	32	
Setting the name of the external component	32	
Selecting the frequency cutoff point	32	
Detaching the control panel	33	
REMOTE OPERATIONS	34	
Installing the batteries	34	
Using the remote controller	35	
CD CHANGER OPERATIONS	36	
Playing CDs	36	
Selecting CD playback modes	38	
Playing a CD text	38	
EXTERNAL COMPONENT OPERATIONS	39	
Using auxiliary players	39	
Using a subwoofer	39	
DAB TUNER OPERATIONS	40	
Tuning into an ensemble and one of the services	40	
Storing DAB services in memory	42	
Tuning into a preset DAB service	44	
MAINTENANCE	45	
To extend the lifetime of the unit	45	
How to reset your unit	45	
TROUBLESHOOTING	46	
SPECIFICATIONS	47	

Note:

For security reasons, a numbered ID card is provided with this unit, and the same ID number is imprinted on the unit's chassis. Keep the card in a safe place, as it will help the authorities to identify your unit if stolen.

BASIC OPERATIONS

ENGLISH

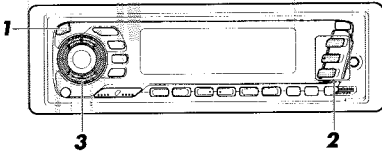

Note:
When you use this unit for the first time, set the built-in clock correctly. (See page 25.)

1 Turn on the power.



Note on One-Touch Operation:
When you select a source in step 2 below, the power automatically comes on. You do not have to press this button to turn on the power.

2 Select the source.

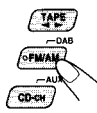

To operate the tuner, see pages 5 – 16.
To operate the cassette deck, see pages 17 – 20.
To operate the CD changer, see pages 36 – 38.
To operate the external component connected to the auxiliary input jack on the front panel, see page 39.
To operate the DAB tuner, see pages 40 – 44.

3 Adjust the volume.

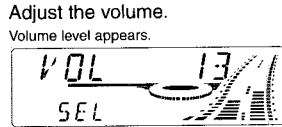
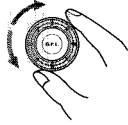

Volume level appears.

4 Adjust the sound as you want (see pages 21 – 24).

To drop the volume in a moment

Press **9/1/ATT** briefly while listening to any source. "ATT" starts flashing on the display, and the volume level will drop in a moment.

To resume the previous volume level, press the button briefly again.

To turn off the power

Press **9/1/ATT** for more than 1 second.

RADIO BASIC OPERATIONS

Listening to the radio

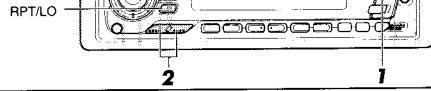

1 Select the band (FM1, FM2, FM3 or AM).
You can select any one of FM1, FM2, and FM3 to listen to an FM station.

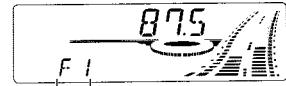
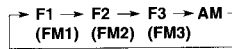

Selected band (or clock time: see page 28) appears.

2 Start searching a station.
When a station is received, searching stops.

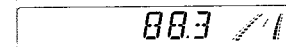
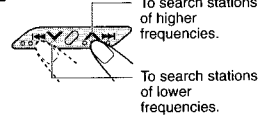

To stop searching before a station is received, press the same button you have pressed for searching.

To tune in a particular frequency without searching:

- 1 Press FM/AM/DAB repeatedly to select the band (FM or AM).
- 2 Press and hold **▲▶▶** or **◀◀▼** until "MANU" starts flashing on the display. Now you can manually change the frequency while "MANU" is flashing.
- 3 Press **▲▶▶** or **◀◀▼** repeatedly until the frequency you want is reached.
 - If you hold down the button, the frequency keeps changing (in 50 kHz intervals for FM and 9 kHz intervals for AM-MW/LW) until you release the button.

To tune in FM stations with only strong signals

Press **RPT/LO** (Repeat/Local) so that the LOCAL indicator lights up on the display. Each time you press the button, the LOCAL indicator lights up and goes off alternately.

Note:

This function only works while searching FM stations including SSM preset (see page 6).

ENGLISH

5

Storing stations in memory

You can use one of the following two methods to store broadcasting stations in memory.

- Automatic preset of FM stations: SSM (Strong-station Sequential Memory)
- Manual preset of both FM and AM stations

FM station automatic preset: SSM

You can preset 6 local FM stations in each FM band (FM1, FM2 and FM3).

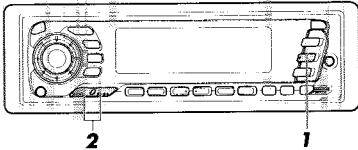

1 Select the FM band number (FM1, FM2 or FM3) you want to store FM stations into.

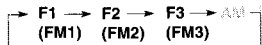

2 Press and hold both buttons for more than 2 seconds.

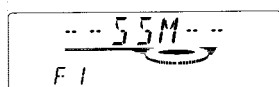
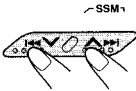

"SSM" appears, then disappears when automatic preset is over.

Local FM stations with the strongest signals are searched and stored automatically in the band number you have selected (FM1, FM2 or FM3). These stations are preset in the number buttons — No. 1 (lowest frequency) to No. 6 (highest frequency).
When automatic preset is over, the station stored in number button 1 will be automatically tuned in.

Manual preset

You can preset up to 6 stations in each band (FM1, FM2, FM3 and AM) manually.

EXAMPLE: Storing an FM station of 88.3 MHz into the preset number 1 of the FM1 band

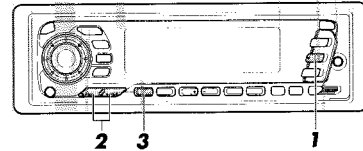

1 Select the FM1 band.

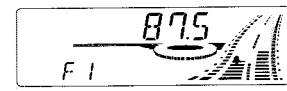

2 Tune into a station of 88.3 MHz.
See page 5 to tune into a station.

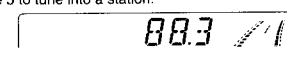

3 Press and hold the number button (in this example, 1) for more than 2 seconds.



Preset number and "MEMO" flashes alternately for a while.

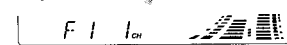

4 Repeat the above procedure to store other stations into other preset numbers.

Notes:

- A previously preset station is erased when a new station is stored in the same preset number.
- Preset stations are erased when the power supply to the memory circuit is interrupted (for example, during battery replacement). If this occurs, preset the stations again.

ENGLISH

7

RDS OPERATIONS

Tuning into a preset station

You can easily tune into a preset station. Remember that you must store stations first. If you have not stored them yet, see pages 6 and 7.

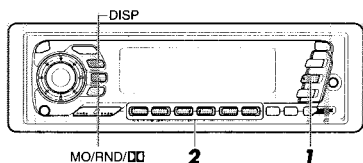

1 Select the band (FM1, FM2, FM3 or AM) you want.



F1 → F2 → F3 → AM
(FM1) (FM2) (FM3)

2 Select the number (1 – 6) for the preset station you want.

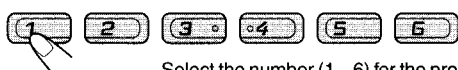

To change the display information while receiving an FM RDS station

Press DISP. Each time you press the button, the display changes as follows:

→ PS (Station name) → Station Frequency → PTY (Programme type)

When an FM stereo broadcast is hard to receive:

Press MO/RND/DO (Mono/Random) while listening to an FM stereo broadcast. The MO (Mono) indicator lights up on the display. The sound you hear becomes monaural but reception will be improved.



To restore the stereo effect, press the button again.

What you can do with RDS EON

RDS (Radio Data System) allows FM stations to send an additional signal along with their regular programme signals. For example, the stations send their station names, as well as information about what type of programme they broadcast, such as sports or music, etc. Another advantage of RDS function is called "EON (Enhanced Other Networks)." The EON indicator lights up while receiving an FM station with the EON data. By using the EON data sent from a station, you can tune into a different station of a different network broadcasting your favorite programme or traffic announcement while listening to another programme or to another source such as tape.

By receiving the RDS data, this unit can do the following:

- Tracing the same programme automatically (Network-Tracking Reception)
- Standby Reception of TA (Traffic Announcement) or your favorite programme
- PTY (Programme Type) search
- TP (Traffic Programme) search
- And some other functions

Tracing the same programme automatically (Network-Tracking Reception)

When driving in an area where FM reception is not good, the tuner built in this unit automatically tune in another RDS station, broadcasting the same programme with stronger signals. So, you can continue to listen to the same programme in its finest reception, no matter where you drive. (See the illustration on the next page.)

Two types of the RDS data are used to make Network-Tracking Reception work correctly — PI (Programme Identification) and AF (Alternative Frequency).

Without receiving these data correctly from the RDS station you are listening to, Network-Tracking Reception will not operate.



To use Network-Tracking Reception, press and hold TP/RDS (Traffic Programme/Radio Data System) for more than 1 second. Each time you press and hold the button, Network-Tracking Reception modes change as follows:

Mode 1 → Mode 2 → Mode 3

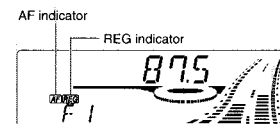

Mode 1

The AF indicator lights up but the REG indicator does not. Network-Tracking is activated with Regionalization set to "off." Switches to another station within the same network when the receiving signals from the current station become weak.

Note:
In this mode, the programme may differ from the one currently received.

Mode 2

Both the AF indicator and the REG indicator light up. Network-Tracking is activated with Regionalization set to "on." Switches to another station, within the same network, broadcasting the same programme when the receiving signals from the current station become weak.

Mode 3

Neither the AF indicator nor the REG indicator lights up. Network-Tracking is deactivated.

The same programme can be received on different frequencies.

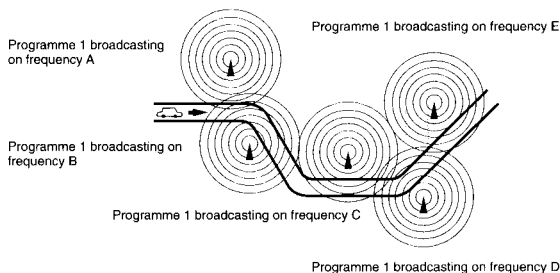

Using Standby Reception

Standby Reception allows the unit to switch temporarily to your favorite programme (PTY: Programme Type) and Traffic Announcement (TA) from the current source (another FM station, tape, CD and other connected components).

Note:
Standby Reception will not work if you are listening to an AM station.

TA Standby Reception



- When you press TP/RDS while listening to an FM station, the TP indicator is lit during reception of a TP (Traffic Programme) station and the TA standby mode is engaged.

Note:
When the station being received is not a TP station, the TP indicator flashes. Press **▶▶▶** or **◀◀◀** to engage the TA standby mode. "SEARCH" appears on the display, and TP station search starts. When a TP station is tuned in, the TP indicator is lit.

- If you are listening to a tape or CD, and wish to listen to a TP station, press TP/RDS to enter the TA standby mode. (The TP indicator lights up.)

If a traffic programme starts broadcasting while the TA standby mode is active, "TRAFFIC" appears and the playback source changes to the FM band. The volume increases to the preset TA volume level and the traffic programme can be heard (see page 15).

To deactivate the TA standby mode, press TP/RDS again.

PTY Standby Reception



- When you press PTY while listening to an FM station, the PTY indicator is lit during reception of a PTY station and the PTY standby mode is engaged. The selected PTY name stored on page 13 flashes for 5 seconds.

Note:
When the station being received is not a PTY station, the PTY indicator flashes. Press **▶▶▶** or **◀◀◀** to engage the PTY standby mode. "SEARCH" appears on the display, and PTY station search starts. When a PTY station is tuned in, the PTY indicator is lit.

- If you are listening to a tape or CD, and wish to listen to a selected PTY broadcast, press PTY to enter the PTY standby mode. (The PTY indicator lights up.)

If the selected PTY programme starts broadcasting while the PTY standby mode is active, the selected PTY name appears and the playback source changes to the FM band. The selected PTY programme can then be heard.

To deactivate the PTY standby mode, press PTY again.



Selecting Your Favorite Programme for PTY Standby Reception

You can select your favorite programme for PTY Standby Reception to store in memory. When shipped from the factory, "NEWS" is stored as the programme type for PTY Standby Reception.

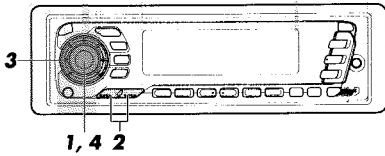

- 1** Press and hold SEL (select) for more than 2 seconds to call up the Preferred Setting Mode (PSM: see page 26).
- 2** Select "PTY STBY (standby)" if not shown on the display.
- 3** Select one of twenty-nine PTY codes. (See page 16.) Selected code name appears on the display and is stored into memory.
- 4** Finish the setting.

Searching Your Favorite Programme

You can search one of your 6 favorite programme types stored in memory. When shipped from the factory, the following 6 programme types have been stored in the number buttons (1 to 6).
 To change the factory preset settings, see page 13.
 To search your favorite programme, see page 14.

1	2	3	4	5	6
POP M	ROCK M	EASY M	CLASSICS	AFFAIRS	VARIED



To search your favorite programme type

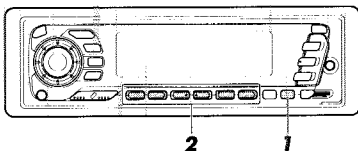

- 1** Press and hold PTY (programme type) for more than 1 second while listening to an FM station. The last selected PTY code and preset number appear.
- 2** Select one of PTY codes stored in preset number buttons (1 to 6).

Ex. When "ROCK M" is stored in preset number button 2.

PTY search for your favorite programme starts after 5 seconds.

- If there is a station broadcasting a programme of the same PTY code you selected, that station is tuned in.
- If there is no station broadcasting a programme of the same PTY code you selected, the station will not change.

Note:
 In some areas, the PTY search will not work correctly.

To store your favorite programme types

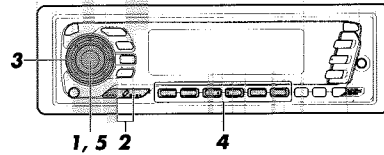

- 1** Press and hold SEL (select) for more than 2 seconds to call up the Preferred Setting Mode (PSM: see page 26).
- 2** Select "PTY SRCH (search)" if not shown on the display.
- 3** Select one of twenty-nine PTY codes. (See page 16.) Selected code name appears on the display.
 • If the code already stored in memory is selected, it will flash on the display.
- 4** Press and hold the number button for more than 2 seconds to store the PTY code selected into the preset number you want. PTY preset number appears, and selected code name and "MEMORY" alternates on the display.
- 5** Finish the setting.

ENGLISH

Other convenient RDS functions and adjustments

Automatic selection of the station when using the number buttons

Usually when you press the number button, the preset station is tuned in. However, when the preset station is an RDS station, something different will happen. If the signals from that preset station are not sufficient for good reception, this unit starts searching another station broadcasting the same programme as the original preset station is broadcasting, then if any station broadcasting the same programme is found, the station will be tuned in.

Changing the display mode while listening to an FM station

You can change the initial indication on the display to either station name (PS) or to station frequency, while listening to an FM RDS station.
 • See also "Changing the general settings (PSM)" on page 26.

1. Press and hold SEL (select) for more than 2 seconds so that "PSM" appears on the lower part of the display.
2. Select "TU DISP (tuner display)" with or .
3. Set to the desired indication (either station name or station frequency) with the control dial.

Note:
 By pressing DISP, you can also change the display while listening to an FM RDS station. Each time you press the button, the following information appears on the upper part of the display:



* Then, the display goes back to the original indication in several seconds.

Setting the TA volume level

You can preset the volume level for TA Standby Reception. When a traffic programme is received, the volume level automatically changes to the preset level.
 • See also "Changing the general settings (PSM)" on page 26.

1. Press and hold SEL (select) for more than 2 seconds so that "PSM" appears on the lower part of the display.
2. Select "TA VOL (volume)" with or .
3. Set to the desired volume with the control dial.

ENGLISH



TAPE OPERATIONS

ENGLISH

Automatic clock adjustment

When shipped from the factory, the clock built in this unit is set to be readjust automatically using the CT (Clock Time) data in the RDS signal.

- If you do not want to use automatic clock adjustment, follow the procedure below.
- See also "Changing the general settings (PSM)" on page 26.

1. Press and hold SEL (select) for more than 2 seconds so that "PSM" appears on the lower part of the display.
2. Select "AUTO ADJ (adjust)" with $\blacktriangle\blacktriangleright$ or $\blacktriangleleft\blacktriangleleft$.
3. Select "OFF" by turning the control dial counterclockwise. Now automatic clock adjustment is canceled.

To reactivate clock adjustment, repeat the same procedure and select "ON" in step 3 by turning the control dial clockwise.

Note:

It takes about 2 minutes to adjust the time using the CT data. So, you must tune to the station for more than 2 minutes continuously; otherwise, the clock time will not be adjusted.

PTY codes

NEWS:	News	SOCIAL:	Programmes on social activities
AFFAIRS:	Topical programmes expanding on current news or affairs	RELIGION:	Programmes dealing with any aspect of belief or faith, or the nature of existence or ethics
INFO:	Programmes which impart advice on a wide variety of topics	PHONE IN:	Programmes where people can express their views either by phone or in a public forum
SPORT:	Sport events	TRAVEL:	Programmes about travel destinations, package tours, and travel ideas and opportunities
EDUCATE:	Educational programmes	LEISURE:	Programmes concerned with recreational activities such as gardening, cooking, fishing, etc.
DRAMA:	Radio plays	JAZZ:	Jazz music
CULTURE:	Programmes on national or regional culture	COUNTRY:	Country music
SCIENCE:	Programmes on natural science and technology	NATION M:	Current popular music from another nation or region, in that country's language
VARIED:	Other programmes like comedies or ceremonies	FOLK M:	Folk music
POP M:	Pop music	DOCUMENT:	Programmes dealing with factual matters, presented in an investigative style
ROCK M:	Rock music		
EASY M:	Easy-listening music		
LIGHT M:	Light music		
CLASSICS:	Classical music		
OTHER M:	Other music		
WEATHER:	Weather information		
FINANCE:	Reports on commerce, trading, the Stock Market, etc.		
CHILDREN:	Entertainment programmes for children		

16

ENGLISH

Listening to a tape

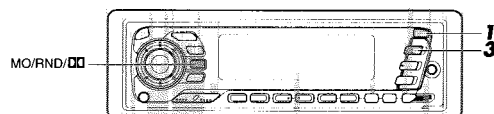

1 Open the control panel.

2 1. Insert a cassette into the cassette compartment. The unit turns on and tape play starts automatically.
2. Close the control panel by hand.

- When one side of the tape reaches its end during play, the other side of the tape automatically starts playing. (Auto Reverse)

Note on One-Touch Operation:

When a cassette is already in the cassette compartment, pressing TAPE ◀ ▶ turns on the unit and starts tape play automatically.

3 Select the tape direction. Each time you press the button, the tape direction changes alternately – forward (FWD PLAY) and reverse (REV PLAY).

To play back tapes recorded with the Dolby B NR

Press the MO/RND/□ button to set the Dolby B NR* system as required in step 2 above. The □ indicator lights up, and "DOLBY B" appears on the display for several seconds. To cancel the Dolby B NR, press the same button again.

* Dolby noise reduction manufactured under license from Dolby Laboratories Licensing Corporation. "DOLBY" and the double-D symbol □ are trademarks of Dolby Laboratories Licensing Corporation.

17



To stop play and eject the cassette

Press \blacktriangle . Tape play stops and the cassette automatically ejects from the cassette compartment. If you change the source to FM, AM, CD changer or AUX, the tape play also stops (without ejecting the cassette this time).

- You can also eject the cassette with the unit turned off.

To fast-forward and rewind a tape

- Press $\blacktriangle\blacktriangleright$ for more than 1 second to fast-forward the tape. When the tape reaches its end, the tape is reversed and playback starts from the beginning of the other side.
- Press $\blacktriangleleft\blacktriangleleft$ for more than 1 second to rewind the tape. When the tape reaches its end, playback of the same side starts.

To stop fast forward and rewind at any position on the tape, press TAPE ◀ ▶. Tape play starts from that position on the tape.

Note:

While fast-forwarding or rewinding, this unit changes the source to the tuner. (Tuner Call Play) If you do not want to use Tuner Call Play, you can cancel this function. See page 20 for details.

Automatic tape type detection

With the Automatic Tape Type Detection mechanism provided for this unit, you can listen to type I, II and IV tapes without changing any settings.

Prohibiting cassette ejection

You can prohibit the cassette ejection and can "lock" a cassette in the cassette compartment. Press and hold TAPE ◀ ▶ and □/I/ATT for more than 2 seconds. "NO EJECT" flashes on the display for about 5 seconds, and the cassette is "locked."

To cancel the prohibition and "unlock" the cassette, press and hold TAPE ◀ ▶ and □/I/ATT for more than 2 seconds again. "EJECT OK" flashes for about 5 seconds, and this time the cassette is "unlocked."

18



Finding the beginning of a tune

Multi Music Scan allows you to automatically start playback from the beginning of a specified tune. You can specify up to 9 tunes ahead of or before the current tune.

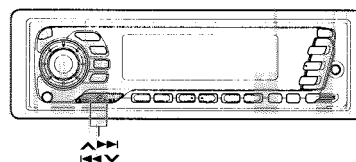

During playback

- To locate a tune ahead of the current tune on the tape
 - To locate a tune before the current tune on the tape
- Specify how many tunes ahead of or before the current tune the tune you want is located.



Each time you set the tune, the number changes up to ±9.

When the beginning of the specified tune is located, playback starts automatically.

Notes:

- While locating a specified tune:
 - If the tape is rewound to its beginning, playback starts from the beginning of that side.
 - If the tape is fast-forwarded to the end, it is reversed and played from the beginning of the other side.
- In the following cases, the Multi Music Scan function may not operate correctly:
 - Tapes with tunes having long pianissimo passages (very quiet parts) or non-recorded portions between tunes.
 - Tapes with short non-recorded sections.
 - Tapes with high level of noise or humming between tunes.
 - The Dolby NR setting does not match. For example, if Dolby B NR is on and the tape was recorded with no Dolby NR.

19

Other convenient tape functions

Turning on/off Tuner Call Play

When you start fast-forwarding or rewinding a tape, the source changes to the tuner temporarily and you can listen to the last received station. After fast forward or rewind is stopped, tape play resumes automatically. When shipped from the factory, Tuner Call Play has been activated.

- See also "Changing the general settings (PSM)" on page 26.

1. Press and hold SEL (select) for more than 2 seconds so that "PSM" appears on the lower part of the display.
 2. Select "TU CALL (tuner call)" with or .
 3. Set to the desired mode with the control dial.
- The Tuner Call Play mode alternates between on and off.

Skipping the blank portions on the tape

You can skip blank portions between the tunes. (Blank Skip)
When this function is on, the unit skips blank portions of 15 seconds or more, fast-forwards to the next tune, then starts playing it.

- See also "Changing the general settings (PSM)" on page 26.

1. Press and hold SEL (select) for more than 2 seconds so that "PSM" appears on the lower part of the display.
 2. Select "B. SKIP (blank skip)" with or .
 3. Select the desired mode with the control dial.
- The Blank Skip mode alternates between on and off.

Note:
When the tape reaches its end while fast-forwarding, the tape direction will be changed automatically.

Playing the current tune repeatedly

You can play the current tune repeatedly. (Repeat Play)



Each time you briefly press RPT/LO (Repeat/Local) while playing a tape, Repeat Play turns on and off alternately.



Lights up when Repeat Play is turned on.

- Notes:**
- In the following cases, Blank Skip and Repeat Play may not operate correctly:
 - Tapes with tunes having long pianissimo passages (very quiet parts) or non-recorded portions during tunes.
 - Tapes with short non-recorded sections.
 - Tapes with high level noise or humming between tunes.
 - The Dolby NR setting does not match. For example, if Dolby B NR is on and the tape was recorded with no Dolby NR.

Selecting preset sound modes

You can select a preset sound adjustment suitable to the music genre.

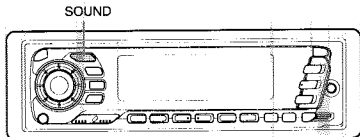

Each time you press SOUND, the sound control mode (SCM) changes as follows.

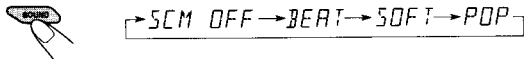

Indication	For:	Preset values		
		Bass	Treble	BBE
SCM OFF	(Flat sound)	00	00	On
BEAT	Rock or disco music	+02	00	On
SOFT	Quiet background music	+01	-03	Off
POP	Light music	+04	+01	Off

- Notes:**
- You can adjust the preset sound control mode to your preference, and store in memory. If you want to adjust and store your original sound control mode, see "Storing your own sound adjustments" on page 24.
 - To adjust only the bass and treble reinforcement levels to your preference, see "Adjusting the sound" on page 23.



Turning on/off the BBE function

The BBE* function restores the brilliance and clarity of the original live sound in recording, broadcasts, etc.
When a speaker reproduces sound, it introduces frequency-dependent phase shifting, causing high-frequency sounds to take longer to reach the ear than low frequency sounds. The BBE function adjusts the phase relationship between the low, mid and high frequencies by adding a progressively longer delay time to the low and mid frequencies, so that all frequencies reach the listener's ears at the proper time.
In addition, the BBE function boosts low and high frequencies, which loudspeakers tend to be less efficient in reproducing, through dynamic, program-driven augmentation. When combined with the phase compensation feature, the resulting sound has a clearer, more finely detailed "live" presence.

Each time you press BBE, the BBE function turns on and off alternately.



* Under license from BBE Sound, Inc.
BBE is a trademark of BBE Sound, Inc.

Adjusting the sound

You can adjust the sound characteristics to your preference.

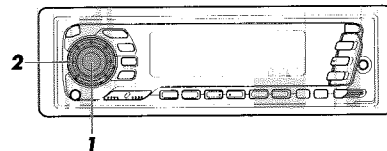

1 Select the item you want to adjust.

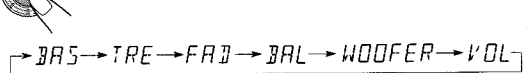

Indication	To do:	Range
BAS (Bass)	Adjust the bass	-06 (min.) — +06 (max.)
TRE (Treble)	Adjust the treble	-06 (min.) — +06 (max.)
FAD (Fader)*	Adjust the front and rear speaker balance	R06 (rear only) — F06 (front only)
BAL (Balance)	Adjust the left and right speaker balance	L06 (left only) — R06 (right only)
WOOFER (Subwoofer)	Adjust the subwoofer	0 (min.) — 8 (max.)
VOL (Volume)	Adjust the volume	00 (min.) — 50 (max.)

Note:
* If you are using a two-speaker system, set the fader level to "00."

2 Adjust the level.

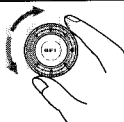

Note:
Normally the control dial works as the volume control. So you do not have to select "VOL" to adjust the volume level.

OTHER MAIN FUNCTIONS



Storing your own sound adjustments

You can adjust the sound modes (BEAT, SOFT, POP; see page 22) to your preference and store your own adjustments in memory.

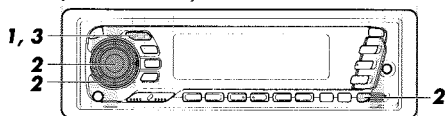

- 1** Call up the sound mode you want to adjust. See page 22 for details.
- 2** **Within 5 seconds**
 To adjust the bass or treble level
 [1] Select "BAS" or "TRE."
 [2] Adjust the bass or treble level.
Within 5 seconds
 To turn on or off the BBE function
 See page 21.
- 3** **Within 5 seconds**
 Press and hold SOUND until the sound mode you selected flashes on the display. Your setting is stored in memory.
- 4** Repeat the same procedure to store other settings.

To reset to the factory settings

Repeat the same procedure and reassign the preset values listed in the table on page 22.

Setting the clock

You can also set the clock system either to 24 hours or 12 hours.

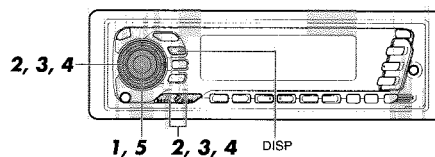

- 1** Press and hold SEL (select) for more than 2 seconds so that one of the PSM items appears on the display.
- 2** [1] Select "CLOCK H (Hour)" if not shown on the display.
[2] Adjust the hour.
- 3** [1] Select "CLOCK M (Minute)."
[2] Adjust the minute.
- 4** [1] Select "24H/12H."
[2] Select "24H" or "12H."
- 5** Finish the setting.

To check the current clock time while the unit is turned off, press DISP. The power turns on, the clock time is shown for 5 seconds, then the power turns off.



Changing the general settings (PSM)

You can change the items listed on the next page by using the PSM (Preferred Setting Mode) control.

Basic Procedure

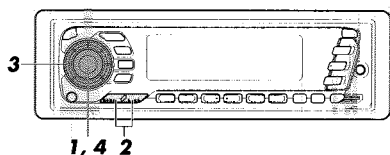

- 1** Press and hold SEL (select) for more than 2 seconds so that one of the PSM items appears on the display.
- 2** Select the PSM item you want to adjust. (See page 27.)
- 3** Select or adjust the PSM item selected above.
- 4** Finish the setting.



1	2	3	Factory-preset settings	See page
Select.	Hour adjustment	Back Advance	0:00	25
	Minute adjustment	Back Advance		
	24H/12H	12H 24H	24H	25
	AUTO ADJ	Automatic setting of the clock	OFF ON	ON 16
	CLOCK	Clock display	OFF ON	ON 28
	TU DISP	Tuner display mode	FREQ PS NAME	PS NAME 15
	CH DISP	CD Text display	P-TIME ↔ D-TITLE ↕ T-TITLE ↕	P-TIME 28
	PTY STBY	PTY standby	29 programme types	NEWS 12
	PTY SRCH	PTY search	(See page 16.)	(See page 12.) 12
	TA VOL	Traffic announcement volume	VOL (00-50)	VOL (20) 15
	LEVEL	Level display	OFF AUDIO	AUDIO 28
	DIMMER	Dimmer	AUTO ↔ OFF ↕ ON ↕	AUTO 29
	CRUISE	Audio cruise	OFF ↔ CRUISE 1 ↕ CRUISE 2 ↕	OFF 29
	RPM SET*	Idling speed	—	800 rpm 30
	BOOST*	Boost	01 - 15	05 30
	TEL	Audio mute for cellular phone system	OFF ↔ MUTING 1 ↕ MUTING 2 ↕	OFF 31
	BEEP	Key-touch tone	OFF ON	ON 31
	P-AMP SW	Power amplifier switch	OFF ON	ON 31
	SCROLL	Name display	ONCE ↔ AUTO ↕ OFF ↕	ONCE 32
	AUX	Auxiliary component	EXTRA ↔ TV ↔ VIDEO ↕ CD ↔ MD ↕	EXTRA 32
	CUTOFF F	Frequency cutoff point	MID ↔ HIGH ↕ LOW ↕	MID 32
	B.SKIP	Blank skip	OFF ON	OFF 20
	TU CALL	Tuner call	OFF ON	ON 20

* When you select "CRUISE 1" or "CRUISE 2" for Audio Cruise Mode, you can adjust these items.

• Press SEL (select) when the setting is complete.



ENGLISH

Selecting the clock display

You can select either the clock or the source name to be shown on the lower part of the display. When shipped from the factory, the clock is selected.

- ON: Clock
- OFF: Source name (or station band)

1. Press and hold SEL (select) for more than 2 seconds so that "PSM" appears on the lower part of the display.
 2. Select "CLOCK" with $\blacktriangle\blacktriangleright$ or $\blacktriangleleft\blacktriangleleft$.
 3. Select the desired mode with the control dial.
- The clock display mode alternates between on and off.

ON \leftrightarrow OFF

To check the other information during play

Press DISP (display). Each time you press the button, the other information (either the clock or the source name) will be shown on the lower part of the display for a while.

Selecting the CD Text information display

You can select what type of the CD Text information to be shown on the display while a CD Text is playing. When shipped from the factory, the playing time is selected.

- P-TIME: Playing time (elapsed) appears on the display.
- D-TITLE: Disc title appears on the display.
- T-TITLE: Track titles appear on the display.

1. Press and hold SEL (select) for more than 2 seconds so that "PSM" appears on the lower part of the display.
 2. Select "CH DISP (display)" with $\blacktriangle\blacktriangleright$ or $\blacktriangleleft\blacktriangleleft$.
 3. Select the desired mode with the control dial.
- The CD Text information display mode changes as follows:

$\blacktriangle\blacktriangleright$ P-TIME \leftrightarrow D-TITLE \leftrightarrow T-TITLE $\blacktriangleleft\blacktriangleleft$

To check the other information during play

Press DISP (display). Each time you press the button, the other information (playing time, disc title, and track titles) will be shown on the upper part of the display for a while.

Selecting the level display

You can select the level display according to your preference. When shipped from the factory, the level indicator on the display shows the audio level.

- AUDIO: Audio level indicator
- OFF: Volume level indicator

1. Press and hold SEL (select) for more than 2 seconds so that "PSM" appears on the lower part of the display.
 2. Select "LEVEL" with $\blacktriangle\blacktriangleright$ or $\blacktriangleleft\blacktriangleleft$.
 3. Select the desired mode with the control dial.
- The level display setting changes as follows:

AUDIO \leftrightarrow OFF



ENGLISH

To adjust the volume increase rate

If you find Audio Cruise increases (or decreases) the volume either too much or too little as the driving speed changes. You can adjust the increase rate by changing the boost level. To change it, follow the procedure below.

1. Press and hold SEL (select) for more than 2 seconds so that "PSM" appears on the lower part of the display.
 2. Select "CRUISE" with $\blacktriangle\blacktriangleright$ or $\blacktriangleleft\blacktriangleleft$.
 3. Select either "CRUISE 1" or "CRUISE 2" with the control dial.
 4. Select "BOOST" with $\blacktriangle\blacktriangleright$ or $\blacktriangleleft\blacktriangleleft$.
- The current boost level appears on the display.
5. Select the desired boost level (among 01 to 15) as you want while the current boost level is shown on the display with the control dial.
 - To increase the volume increase rate, rotate it clockwise.
 - To decrease the volume increase rate, rotate it counterclockwise.

If Audio Cruise does not function correctly

You may need to store the idling speed into memory to make Audio Cruise function correctly.

NOTICE that a number of factors, such as electric power steering, wipers, power windows, air conditioner, etc. do generate noises and, as a result, may cause Audio Cruise not to function correctly. If this is the main cause of malfunction, connect the memory backup lead (yellow lead) directly to the car battery to prevent these noises from affecting Audio Cruise.

1. Start the engine and let it warm up.
2. Press and hold SEL (select) for more than 2 seconds so that "PSM" appears on the lower part of the display.
3. Select "CRUISE" with $\blacktriangle\blacktriangleright$ or $\blacktriangleleft\blacktriangleleft$.
4. Select either "CRUISE 1" or "CRUISE 2" with the control dial.
5. Select "RPM SET" with $\blacktriangle\blacktriangleright$ or $\blacktriangleleft\blacktriangleleft$.
6. Select the desired idling speed as you want with the control dial.

When the setting is complete, the unit automatically checks to see if Audio Cruise functions correctly with this new idling setting. If it does not function correctly, Audio Cruise is canceled automatically and the idling setting becomes invalid.

- If this happens, see the **NOTICE** above.



ENGLISH

Selecting the dimmer mode

When you turn on the car head lights, the display automatically dims (Auto Dimmer). When shipped from the factory, Auto Dimmer mode is activated.

- AUTO: Activates Auto Dimmer.
- ON: Always dims the display.
- OFF: Cancels Auto Dimmer.

1. Press and hold SEL (select) for more than 2 seconds so that "PSM" appears on the lower part of the display.
 2. Select "DIMMER" with $\blacktriangle\blacktriangleright$ or $\blacktriangleleft\blacktriangleleft$.
 3. Select the desired mode with the control dial.
- The dimmer mode changes as follows:

$\blacktriangle\blacktriangleright$ AUTO \leftrightarrow OFF \leftrightarrow ON $\blacktriangleleft\blacktriangleleft$

Note on Auto Dimmer:

Auto Dimmer equipped with this unit may not work correctly on some vehicles, particularly on those having a control dial for dimming. In this case, set the dimmer mode to "ON" or "OFF".

Controlling the volume automatically (Audio Cruise)

You can select the proper cruise mode for your car.

This unit change the volume level automatically (at 3 possible levels) based on the driving speed of your car by detecting the alternator's generating frequency (Audio Cruise).

If you want to use this mode, follow the procedures below. When shipped from the factory, this mode is set to "OFF".

- CRUISE 1: Select this if your car is relatively quiet.
 - CRUISE 2: Select this if your car is relatively loud.
 - OFF: Cancels Audio Cruise.
- The volume increase rate is twice as much as that of the CRUISE 1 setting.

1. Press and hold SEL (select) for more than 2 seconds so that "PSM" appears on the lower part of the display.
 2. Select "CRUISE" with $\blacktriangle\blacktriangleright$ or $\blacktriangleleft\blacktriangleleft$.
 3. Select the desired mode with the control dial.
- The cruise mode changes as follows:

$\blacktriangle\blacktriangleright$ OFF \leftrightarrow CRUISE 1 \leftrightarrow CRUISE 2 $\blacktriangleleft\blacktriangleleft$

When this function is turned on (the CRUISE indicator lights up on the display), the proper volume level is automatically selected among the 3 possible levels according to the driving speed, and the selected level is shown on the display.

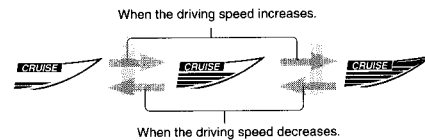

ENGLISH

Selecting the telephone muting

This mode is used when a cellular phone system is connected. Depending on the phone system used, select either "MUTING 1" or "MUTING 2," whichever mutes the sounds from this unit. When shipped from the factory, this mode is deactivated.

- MUTING 1: Select this if this setting can mute the sounds.
- MUTING 2: Select this if this setting can mute the sounds.
- OFF: Cancels the telephone muting.

1. Press and hold SEL (select) for more than 2 seconds so that "PSM" appears on the lower part of the display.
 2. Select "TEL (telephone)" with $\blacktriangle\blacktriangleright$ or $\blacktriangleleft\blacktriangleleft$.
 3. Select the desired mode with the control dial.
- The telephone muting mode changes as follows:

$\blacktriangle\blacktriangleright$ MUTING 1 \leftrightarrow MUTING 2 \leftrightarrow OFF $\blacktriangleleft\blacktriangleleft$

Turning on/off the key-touch tone

You can deactivate the key-touch tone if you do not want to make it beep when you press a button. When shipped from the factory, the key-touch tone is activated.

- ON: Activates the key-touch tone.
- OFF: Deactivates the key-touch tone.

1. Press and hold SEL (select) for more than 2 seconds so that "PSM" appears on the lower part of the display.
 2. Select "BEEP" with $\blacktriangle\blacktriangleright$ or $\blacktriangleleft\blacktriangleleft$.
 3. Select the desired mode with the control dial.
- The key-touch tone alternates between on and off.

ON \leftrightarrow OFF

Turning on/off the power amplifier switch

You can switch off the built-in amplifier and send the audio signals only to the external amplifier(s) to get clear sounds and to prevent internal heat buildup inside this unit. When shipped from the factory, the power amplifier switch is turned on so that built-in amplifier works.

- ON: Select this mode when not using external power amplifier(s).
- OFF: Select this mode when using external power amplifier(s).

1. Press and hold SEL (select) for more than 2 seconds so that "PSM" appears on the lower part of the display.
 2. Select "P-AMP SW (power amplifier switch)" with $\blacktriangle\blacktriangleright$ or $\blacktriangleleft\blacktriangleleft$.
 3. Select the desired mode with the control dial.
- The power amplifier switch alternates between on and off.

ON \leftrightarrow OFF

Selecting the scroll mode

You can select the scroll mode for the name display and disc information if it consists of more than 8 characters. When shipped from the factory, Auto Scroll mode is set to "ONCE."

- ONCE: Scrolls only once.
- AUTO: Repeats the scroll (5-second intervals in between).
- OFF: Cancels Auto Scroll.

1. Press and hold SEL (select) for more than 2 seconds so that "PSM" appears on the lower part of the display.
2. Select "SCROLL" with $\blacktriangle\blacktriangleright$ or $\blacktriangleleft\blacktriangleleft$.
3. Select the desired mode with the control dial.

The scroll mode changes as follows:



Note:

Even if the scroll mode is set to "OFF," you can scroll the display by pressing DISP for more than 1 second.

Setting the name of the external component

You can select the name of the external component which will be shown on the upper part of the display when you press CD-CH/AUX. When shipped from the factory, the name of the external component is set to "EXTRA."

1. Press and hold SEL (select) for more than 2 seconds so that "PSM" appears on the lower part of the display.
2. Select "AUX (auxiliary)" with $\blacktriangle\blacktriangleright$ or $\blacktriangleleft\blacktriangleleft$.
3. Select the desired source name with the control dial.

The source name to be shown on the upper part of the display changes as follows:



Selecting the frequency cutoff point

When a subwoofer is connected to the unit, you can select the frequency cutoff point to obtain the response you want. When shipped from the factory, the cutoff point is set to "MID."

- MID: Frequencies higher than 80 Hz are cut off.
- HIGH: Frequencies higher than 120 Hz are cut off.
- LOW: Frequencies higher than 50 Hz are cut off.

1. Press and hold SEL (select) for more than 2 seconds so that "PSM" appears on the lower part of the display.
2. Select "CUTOFF F (frequency)" with $\blacktriangle\blacktriangleright$ or $\blacktriangleleft\blacktriangleleft$.
3. Select the desired mode with the control dial.

The frequencies to be cut off change as follows:



Detaching the control panel

You can detach the control panel when leaving the car. When detaching or attaching the control panel, be careful not to damage the connectors on the back of the control panel and on the panel holder.

How to detach the control panel

Before detaching the control panel, be sure to turn off the power.

1. Unlock the control panel.

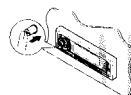

2. Pull the control panel out of the unit.

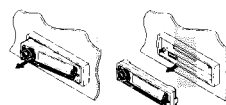

3. Put the detached control panel into the provided case.

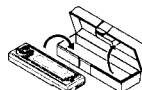

How to attach the control panel

1. Insert the right side of the control panel into the groove on the panel holder.



2. Press the left side of the control panel to fix it to the panel holder.



Note on cleaning the connectors:
If you frequently detach the control panel, the connectors will deteriorate. To minimize this possibility, periodically wipe the connectors with a cotton swab or cloth moistened with alcohol, being careful not to damage the connectors.

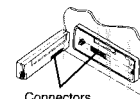

REMOTE OPERATIONS

Before using the remote controller:

- Aim the remote controller directly at the remote sensor on the main unit. Make sure there is no obstacle in between.
- Do not expose the remote sensor to strong light (direct sunlight or artificial lighting).

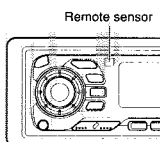

Installing the batteries

When the controllable range or effectiveness of the remote controller decreases, replace the batteries.

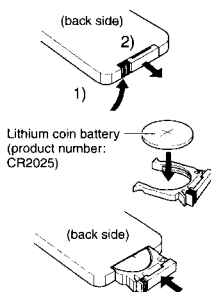

1. **Remove the battery case.**
 - 1) Push in the direction indicated by the arrow with your right hand thumbnail.
 - 2) Remove the battery case.
2. **Replace the battery.**
Put the battery in the case with the + side facing upwards.
3. **Return the battery case.**
Insert again the battery case pushing until you hear a clicking sound.

WARNING:

- Store the batteries in a place which children cannot reach. If a child accidentally swallows the battery, immediately consult a doctor.
- Do not recharge, short, disassemble or heat the batteries or dispose of in a fire. Doing any of these things may cause the batteries to give off heat, crack or start a fire.
- Do not leave the batteries with other metallic materials. Doing this may cause the batteries to give off heat, crack or start a fire.
- When throwing away or saving the batteries, wrap in tape and insulate; otherwise, it may cause the batteries to give off heat, crack or start a fire.
- Do not poke the batteries with tweezers or similar tools. Doing this may cause the batteries to give off heat, crack or start a fire.

Using the remote controller

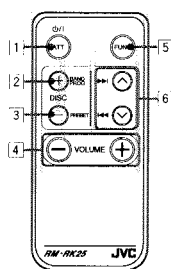

- 1] Functions the same as the \odot /I/ATT button on the main unit.
- 2] • Functions as the BAND button while listening to the radio (or the DAB tuner).
Each time you press the button, the band changes.
• Functions as the DISC + button while listening to the CD changer.
Each time you press the button, the disc number increases, and the selected disc starts playing.
• Functions as the PROG button while listening to a tape.
Each time you press the button, the tape direction changes alternately.
- 3] • Functions as the PRESET button while listening to the radio (or the DAB tuner).
Each time you press the button, the preset station number increases, and the selected station is tuned in.
• Functions as the DISC - button while listening to the CD changer.
Each time you press the button, the disc number decreases, and the selected disc starts playing.
- 4] Functions the same as the control dial on the main unit.
Note: This button does not function for the preferred setting mode adjustment.
- 5] Selects the source.
Each time you press FUNC (function), the source changes.
- 6] • Searches stations while listening to the radio.
• Searches ensembles while listening to the DAB tuner.
• Functions as the fast forward or rewind buttons or Multi Music Scan buttons while listening to a tape.
• Fast-forwards or reverses the track if pressed and held while listening to a CD.
• Skips to the beginning of the next tracks or goes back to the beginning of the current (or previous tracks) if pressed briefly while listening to a CD.

CD CHANGER OPERATIONS

ENGLISH

We recommend that you use one of the CH-X series (ex: CH-X1200) with your unit.
If you have another CD automatic changer, consult your JVC IN-CAR ENTERTAINMENT dealer for connections.

• For example, if your CD automatic changer is one of the KD-MK series, you need a cord (KS-U15K) for connecting it to this unit.

Before operating your CD automatic changer:

- Refer also to the instructions supplied with your CD changer.
- If no discs are in the magazine of the CD changer or the discs are inserted upside down, "NO DISC" will appear on the display. If this happens, remove the magazine and set the discs correctly.
- If "RESET 1 - RESET 8" appears on the display, something is wrong with the connection between this unit and the CD changer. If this happens, check the connection, connect the connecting cord(s) firmly if necessary, then press the reset button of the CD changer.

Playing CDs

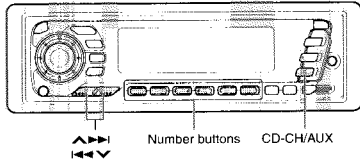

Select the CD automatic changer.

Each time you press the button, you can select the CD automatic changer and the external component alternately.

CD-CH ↔ AUX

Playback starts from the first track of the first disc.
All tracks of all discs are played back.

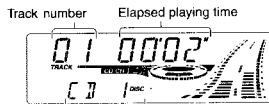

Disc number (or clock time:
see page 28) appears.

Note on One-Touch Operation:

When you press CD-CH/AUX, the power automatically comes on. You do not have to press $\text{O}/\text{I}/\text{ATT}$ to turn on the power.

36



Selecting CD playback modes

To play back tracks at random (Random Play)

Each time you press MO/RND/□□ (Mono/Random) while playing a CD, CD random play mode changes as follows:

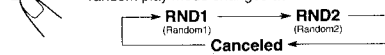

Mode	RND Indicator	Plays at random
RND1	Lights	All tracks of the current disc, then the tracks of the next disc, and so on.
RND2	Flashes	All tracks of all discs inserted in the magazine.

To play back tracks repeatedly (Repeat Play)

Each time you press RPT/L (Repeat/Local) while playing a CD, CD repeat play mode changes as follows:

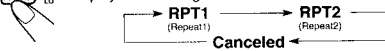

Mode	RPT Indicator	Plays repeatedly
RPT1	Lights	The current track (or specified track).
RPT2	Flashes	All tracks of the current disc (or specified disc).

Playing a CD Text

Only when the CD changer with the CD Text function (ex. CH-X1200) is connected:
In a CD Text, some information about the disc (its disc title, performer and track title) is recorded. You can show these disc information on the display.

Each time you press the button while playing a CD Text, the display changes as follows:

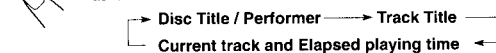

Notes:

- The display shows up to 8 characters at one time and scrolls if there are more than 8 characters. See also "Selecting the scroll mode" on page 32. Some characters or symbols will not be shown (and be blanked) on the display. (Ex. "ABC!d#" ⇒ "ABCA D ")
- When you press DISP while playing a conventional CD, "NO NAME" appears for the disc title/performer and the track title.

38



To fast-forward or reverse the track

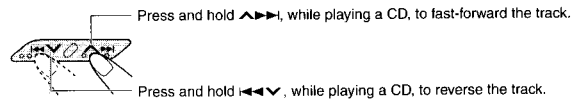

To go to the next tracks or the previous tracks

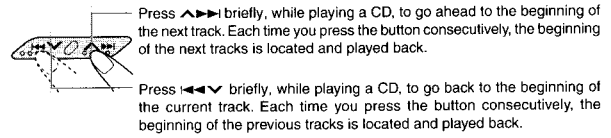

To go to a particular disc directly

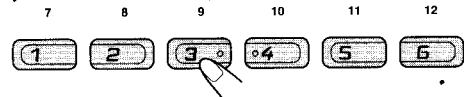

Press the number button corresponding to the disc number to start its playback (while the CD changer is playing).

- To select a disc number from 1 - 6:
Press 1 (7) - 6 (12) briefly.
- To select a disc number from 7 - 12:
Press and hold 1 (7) - 6 (12) for more than 1 second.

Ex. When disc number 3 is selected

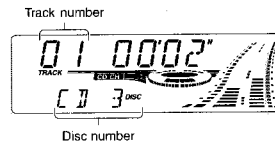

ENGLISH

37

EXTERNAL COMPONENT OPERATIONS

Using auxiliary players

After connecting an external component to the auxiliary input jack on the front panel, you can select the component as the sound source.

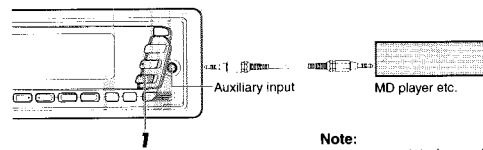

Note:
Use a stereo mini-plug cord to connect an external component to the unit.

1



Select the external component.

Each time you press the button, you can select the CD automatic changer and the external component alternately.

Note:

When selecting an external component as the source, what appears on the upper part of the display depends on the "AUX" setting (see page 32).

Note on One-Touch Operation:

When you press CD-CH/AUX, the power automatically comes on. You do not have to press $\text{O}/\text{I}/\text{ATT}$ to turn on the power.

2

Operate the external component.

- Refer to the instructions supplied with your external component.

Using a subwoofer

By connecting a subwoofer with the SUB WOOFER cord on the rear, enhanced bass sound can add a more realistic, theater atmosphere to your stereo system.

- Refer also to the instructions supplied with your subwoofer.

To select the frequency cutoff point, refer to "Selecting the frequency cutoff point" on page 32.

To adjust the subwoofer volume, refer to "Adjusting the sound" on page 23.

ENGLISH

39

DAB DAB TUNER OPERATIONS

ENGLISH

We recommend that you use DAB (Digital Audio Broadcasting) tuner KT-DB1500 with your unit.
 If you have another DAB tuner, consult your JVC IN-CAR ENTERTAINMENT dealer.
 • Refer also to the instructions supplied with your DAB tuner.

What is DAB system?

DAB is one of the digital radio broadcasting systems available today. It can deliver CD quality sound without any annoying interference and signal distortion. Furthermore, it can carry text, pictures and data.
 In contrast to FM broadcast, where each programme is transmitted on its own frequency, DAB combines several programmes (called "services") to form one "ensemble".
 With the DAB tuner connected with this unit, you can enjoy these DAB services.

Tuning into an ensemble and one of the services

A typical ensemble has 6 or more programmes (services) broadcast at the same time. After tuning into an ensemble, you can select a service you want to listen to.

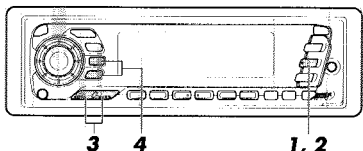

Before you start....

Press FM/AM/DAB briefly if you are selecting TAPE, CD changer or AUX as the source.

1



Select the DAB tuner.

Each time you press and hold the button for more than 1 second, the DAB tuner and the FM/AM tuner are alternately selected.

DAB ↔ FM/AM

2



Select the DAB band (DAB1, DAB2, or DAB3). You can select any one of DAB1, DAB2, and DAB3 to tune into an ensemble.

→ DAB 1 → DAB 2 → DAB 3 →

40

DAB

Storing DAB services in memory

You can preset up to 6 DAB services in each DAB band (DAB1, DAB2 and DAB3) manually.

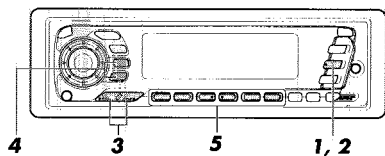

1



Select the DAB tuner.

Each time you press and hold the button, the DAB tuner and the FM/AM tuner are alternately selected.

DAB ↔ FM/AM

2



Select the DAB band (DAB1, DAB2, or DAB3) you want.

Each time you press the button, the DAB band changes as follows:

→ DAB 1 → DAB 2 → DAB 3 →

3



Tune into an ensemble you want.

4

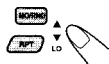

Select a service of the ensemble you want.

42

DAB

ENGLISH

3



To search ensembles of higher frequencies.
 To search ensembles of lower frequencies.

Start searching an ensemble.
 When an ensemble is received, searching stops.

4



Select an service you want to listen to.

To stop searching before an ensemble is received, press the same button you have pressed for searching.

To change the display information while tuning into an ensemble

Normally service name is shown on the upper part of the display.
 If you want to check the ensemble name or its frequency, press DISP.
 Each time you press the button, the following information appears for a while on the part of the display.

→ Service name → Ensemble name → Frequency →

To restore the FM/AM tuner

Press and hold FM/AM/DAB for more than 1 second again.

To tune in a particular ensemble without searching:

- 1 Press and hold FM/AM/DAB for more than 1 second.
- 2 Press FM/AM/DAB repeatedly to select the DAB band (DAB1, DAB2, or DAB3).
- 3 Press and hold $\blacktriangle\blacktriangleright$ or $\blacktriangleleft\blacktriangleleft$ for more than 1 second.
- 4 Press $\blacktriangle\blacktriangleright$ or $\blacktriangleleft\blacktriangleleft$ repeatedly until the ensemble you want is reached.

• If you hold down the button, the frequency keeps changing until you release the button.

41

DAB

ENGLISH

5

Press and hold the number button (in this example, 1) for more than 2 seconds.



Preset number and "MEMO" flashes alternately for a while.

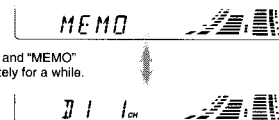

6

Repeat the above procedure to store other DAB services into other preset numbers.

Notes:

- A previously preset DAB service is erased when a new DAB service is stored in the same preset number.
- Preset DAB services are erased when the power supply to the memory circuit is interrupted (for example, during battery replacement). If this occurs, preset the DAB services again.

43



Tuning into a preset DAB service

You can easily tune into a preset DAB service. Remember that you must store services first. If you have not stored them yet, see pages 42 and 43.

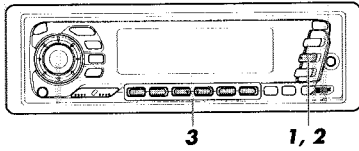

1 Select the DAB tuner. Each time you press and hold the button, the DAB tuner and the FM/AM tuner are alternately selected.



DAB ↔ FM/AM

2 Select the DAB band (DAB1, DAB2, or DAB3) you want. Each time you press the button, the DAB band changes as follows:



→ DAB 1 → DAB 2 → DAB 3

3 Select the number (1 – 6) for the preset DAB service you want.

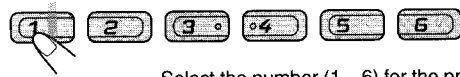

MAINTENANCE ?!

To extend the lifetime of the unit

This unit requires very little attention, but you will be able to extend the life of the unit if you follow the instructions below.

To clean the heads

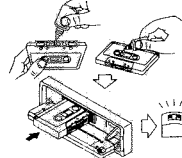

- Clean the heads after every 10 hours of use using a wet-type head cleaning tape (available at an audio store).
- When the head becomes dirty, you may realize the following symptoms:
 - Sound quality is reduced.
 - Sound level decreases.
 - Sound drops out.
- Do not play dirty or dusty tapes.
- Do not touch the highly-polished head with any metallic or magnetic tools.

To keep the tape clean

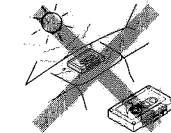

- Always store the tapes to their storage cases after use.
- Do not store tapes in the following places:
 - Subject to direct sunlight
 - With high humidity
 - At extremely hot temperatures

CAUTIONS:

- Do not play the tapes with peeling labels; otherwise, they can damage the unit.
- Tighten tapes to remove slack since loose tape may become entangled with the mechanism.
- Do not leave a cassette in the cassette compartment after use, as the tape may become slack.

The function below is also provided to ensure the longer life of this unit.

Ignition key-off Release/ Ignition key-on play

- When you turn off the ignition key with a cassette in the compartment, the unit automatically releases the tape from its head.
- When you turn on the ignition key with a cassette in the compartment, playback automatically starts.

How to reset your unit

Press and hold both the SEL (select) and O/I/ATT buttons at the same time for several seconds. This will reset the built-in microcomputer.

Note:

Your preset adjustments — such as preset channels or sound adjustments — will also be erased.

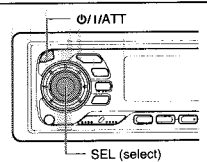

?! TROUBLESHOOTING

What appears to be trouble is not always serious. Check the following points before calling a service center.

Symptoms	Causes	Remedies
• A cassette tape cannot be inserted.	You have tried to insert a cassette in the wrong way.	Insert the cassette with the exposed tape facing right.
• Cassette tapes become hot.	This is not a malfunction.	—
• Tape sound is at very low level and sound quality is degraded.	The tape head is dirty.	Clean it with a head cleaning tape.
• Sound is sometimes interrupted.	Connections are not good.	Check the cords and connections.
• Sound cannot be heard from the speakers.	The volume is turned to the minimum level.	Adjust it to the optimum level.
	Connections are incorrect.	Check the cords and connections.
• SSM (Strong-station Sequential Memory) automatic preset does not work.	Signals are too weak.	Store stations manually.
• Static noise while listening to the radio.	The antenna is not connected firmly.	Connect the antenna firmly.
• "NO DISC" appears on the display.	No CD is in the magazine.	Insert CDs into the magazine.
	CDs are inserted incorrectly.	Insert them correctly.
• "RESET 8" appears on the display.	This unit is not connected to a CD changer correctly.	Connect this unit and the CD changer correctly and press the reset button of the CD changer.
• "RESET 1-RESET 7" appears on the display.	—	Press the reset button of the CD changer.
• This unit does not work at all.	The built-in microcomputer may function incorrectly due to noise, etc.	While holding SEL, press O/I/ATT for several seconds to reset the unit. (The clock setting and preset stations stored in memory are erased.) (See page 45.)
• The CD changer does not work at all.		

SPECIFICATIONS

AUDIO AMPLIFIER SECTION

Maximum Power Output:
 Front: 40 W per channel
 Rear: 40 W per channel
 Continuous Power Output (RMS):
 Front: 16 W per channel into 4 Ω , 40 Hz to 20,000 Hz at no more than 0.8 % total harmonic distortion.
 Rear: 16 W per channel into 4 Ω , 40 Hz to 20,000 Hz at no more than 0.8 % total harmonic distortion.
 Load Impedance: 4 Ω (4 Ω to 8 Ω allowance)
 Tone Control Range:
 Bass: ± 10 dB at 100 Hz
 Treble: ± 10 dB at 10 kHz
 Frequency Response: 40 Hz to 20,000 Hz
 Signal-to-Noise Ratio: 70 dB
 Line-Out Level/Impedance:
 4.0 V/20 k Ω load (250 nWb/m)
 Input: AUX (3.5 mm dia. stereo mini jack)

CASSETTE DECK SECTION

Wow & Flutter: 0.11% (WRMS)
 Fast-Wind Time: 100 sec. (C-60)
 Frequency Response (Dolby NR-OFF):
 30 Hz to 18,000 Hz (Metal/CrO₂ tape)
 30 Hz to 16,000 Hz (Normal tape)
 Signal-to-Noise Ratio: (Normal tape)
 (Dolby NR-ON): 65 dB
 (Dolby NR-OFF): 56 dB
 Stereo Separation: 40 dB

GENERAL

Power Requirement:
 Operating Voltage: DC 14.4 V (11 V to 16 V allowance)
 Allowable Operating Temperature:
 0°C to +40°C
 Grounding System: Negative ground
 Dimensions (W x H x D)
 Installation Size:
 182 mm x 52 mm x 150 mm
 Panel Size: 188 mm x 58 mm x 11 mm
 Mass: 1.4 kg (excluding accessories)

Design and specifications subject to change without notice.

TUNER SECTION

Frequency Range:
 FM: 87.5 MHz to 108.0 MHz
 AM: (MW) 522 kHz to 1,620 kHz
 (LW) 144 kHz to 279 kHz
[FM Tuner]
 Usable Sensitivity: 11.3 dBf (1.0 μ V/75 Ω)
 50 dB Quieting Sensitivity:
 16.3 dBf (1.8 μ V/75 Ω)
 Alternate Channel Selectivity (400 kHz):
 65 dB
 Frequency Response: 40 Hz to 15,000 Hz
 Stereo Separation: 30 dB
 Capture Ratio: 1.5 dB

[MW Tuner]
 Sensitivity: 20 μ V
 Selectivity: 35 dB

[LW Tuner]
 Sensitivity: 50 μ V

JVC KS-FX950R

Installation/Connection Manual Einbau/Anschlußanleitung Manuel d'installation/raccordement

FSUN3124-T211 [E]

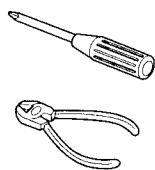

1299MNMMDWJES
EN, GE, FR

ENGLISH

- This unit is designed to operate on 12 volts DC, NEGATIVE ground electrical systems.

INSTALLATION (IN-DASH MOUNTING)

- The following illustration shows a typical installation. However, you should make adjustments corresponding to your specific car. If you have any questions or require information regarding installation kits, consult your JVC IN-CAR ENTERTAINMENT dealer or a company supplying kits.

1 Before mounting: Press (Control Panel Release button) to detach the control panel.

2 Remove the trim plate.

3 Remove the sleeve after disengaging the sleeve locks.

① Stand the unit.

Note: When you stand the unit, be careful not to damage the fuse on the rear.

② Insert the 2 handles between the unit and the sleeve, as illustrated, to disengage the sleeve locks.

③ Remove the sleeve.

Note: Be sure to keep the handles for future use after installing the unit.

4 Install the sleeve into the dashboard.

* After the sleeve is correctly installed into the dashboard, bend the appropriate tabs to hold the sleeve firmly in place, as illustrated.

5 Fix the mounting bolt to the rear of the unit's body and place the rubber cushion over the end of the bolt.

6 Do the required electrical connections explained on the back of this instructions.

7 Slide the unit into the sleeve until it is locked.

8 Attach the trim plate so that the projection on the trim plate is fixed to the left side of the unit.

9 Attach the control panel.

DEUTSCH

- Dieses Gerät ist für einen Betrieb in elektrischen Anlagen mit 12 V Gleichstrom und (-) Erdung ausgelegt.

EINBAU (IM ARMATURENBRETT)

- Die folgende Abbildung zeigt einen typischen Einbau. Dennoch müssen Sie entsprechend Ihrem jeweiligen Auto Anpassungen vornehmen. Bei irgendwelchen Fragen oder wenn Sie Informationen hinsichtlich des Einbausatzes brauchen, wenden Sie sich an Ihren JVC Autoradiohändler oder ein Unternehmen das diese Einbausätze vertreibt.

1 Vor dem Einbau: (Schalttafel-Freigabetaste) zum Lösen der Schalttafel drücken.

2 Den Frontrahmen herausnehmen.

3 Die Halterung nach dem Entriegeln der Halterungssperren abnehmen.

① Das Gerät aufstellen.

Hinweis: Beim Aufstellen des Geräts darauf achten, daß die Sicherung auf der Rückseite nicht beschädigt wird.

② Die beiden Griffe zwischen dem Gerät und der Halterung wie abgebildet einstecken und die Halterungssperren entriegeln.

③ Die Halterung entfernen.

Hinweis: Sicherstellen, daß die Griffe für künftigen Gebrauch nach dem Einbau des Geräts aufbewahrt werden.

4 Die Halterung im Armaturenbrett einbauen.

* Nach dem korrekten Einbau der Halterung im Armaturenbrett, die entsprechenden Riegel umknicken, um die Halterung an ihrem Platz zu sichern, siehe Abbildung.

5 Die Befestigungsschraube an der Rückseite des Gerätekörpers befestigen und das Ende der Schraube mit einem Gummipuffer abdecken.

6 Die elektrischen Verbindungen wie umseitig in dieser Anleitung erklärt ausführen.

7 Das Gerät in die Halterung schieben, bis es einrastet.

8 Befestigen Sie die Frontrahmen in der Form, daß der Fortsatz der Frontrahmen auf der linken Seite des Geräts befestigt wird.

9 Die Schalttafel anbringen.

FRANÇAIS

- Cet appareil est conçu pour fonctionner sur des sources de courant continu de 12 volts à masse NEGATIVE.

INSTALLATION (MONTAGE DANS LE TABLEAU DE BORD)

- L'illustration suivante est un exemple d'installation typique. Cependant, vous devez faire les ajustements correspondant à votre voiture particulière. Si vous avez des questions ou avez besoin d'information sur des kits d'installation, consultez votre revendeur d'autoradios JVC ou une compagnie d'approvisionnement.

1 Avant le montage: Appuyer sur (touche de libération du panneau de commande) pour détacher le panneau de commande.

2 Retirer la plaque d'assemblage.

3 Libérer les verrous du manchon et retirer le manchon.

① Poser l'appareil à la verticale.

Remarque: Lorsque vous mettez l'appareil à la verticale, faire attention de ne pas endommager le fusible situé sur le fond.

② Insérer les 2 poignées entre l'appareil et le manchon comme indiqué pour désengager les verrous de manchon.

③ Retirer le manchon.

Remarque: S'assurer de garder les poignées pour une utilisation ultérieure, après l'installation de l'appareil.

4 Installer le manchon dans le tableau de bord.

* Après installation correcte du manchon dans le tableau de bord, plier les bonnes pattes pour maintenir fermement le manchon en place, comme montré.

5 Monter le boulon de montage sur l'arrière du corps de l'appareil puis passer l'amortisseur en caoutchouc sur l'extrémité du boulon.

6 Réaliser les connexions électriques expliquées au dos de cette page.

7 Faire glisser l'appareil dans le manchon jusqu'à ce qu'il soit verrouillé.

8 Attachez la plaque d'assemblage de façon que la projection de la plaque soit fixée sur le côté gauche de l'appareil.

9 Remonter le panneau de commande.

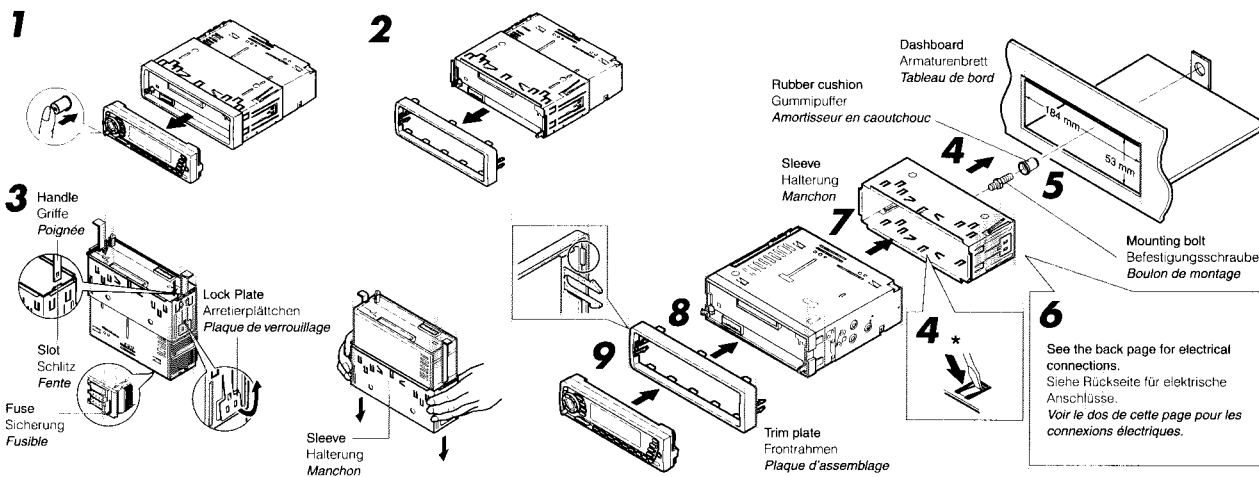

TROUBLESHOOTING

- The fuse blows.**
 - Are the red and black leads connected correctly?
- Power cannot be turned on.**
 - Is the yellow lead connected?
- No sound from the speakers.**
 - Is the speaker output lead short-circuited?
- Sound is distorted.**
 - Is the speaker output lead grounded?
 - Are the "-" terminals of L and R speakers grounded in common?
- Unit becomes hot.**
 - Is the speaker output lead grounded?
 - Are the "-" terminals of L and R speakers grounded in common?

FEHLERSUCHE

- Die Sicherung brennt durch.**
 - Sind die roten und schwarzen Leitungen richtig angeschlossen?
- Stromversorgung kann nicht eingeschaltet werden.**
 - Ist die gelbe Leitung angeschlossen?
- Kein Ton aus den Lautsprechern.**
 - Ist die Lautsprecherausgangsleitung kurzgeschlossen?
- Ton verzerrt.**
 - Ist die Lautsprecherausgangsleitung geerdet?
 - Sind die (-) Anschlußklemmen der linken und rechten Lautsprecher zusammen geerdet?
- Gerät wird heiß.**
 - Ist die Lautsprecherausgangsleitung geerdet?
 - Sind die (-) Anschlußklemmen der linken und rechten Lautsprecher zusammen geerdet?

EN CAS DE DIFFICULTÉS

- Le fusible saute.**
 - Les fils rouge et noir sont-ils raccordés correctement?
- L'appareil ne peut pas être mis sous tension.**
 - Le fil jaune est-elle raccordée?
- Pas de son des haut-parleurs.**
 - Le fil de sortie de haut-parleur est-il court-circuité?
- Le son est déformé.**
 - Le fil de sortie de haut-parleur est-il à la masse?
 - Les bornes "-" des haut-parleurs gauche et droit sont-elles mises ensemble à la masse?
- L'appareil devient chaud.**
 - Le fil de sortie de haut-parleur est-il à la masse?
 - Les bornes "-" des haut-parleurs gauche et droit sont-elles mises ensemble à la masse?

- When using the optional stay
- Beim Verwenden der Anker-Option
- Lors de l'utilisation du hauban en option

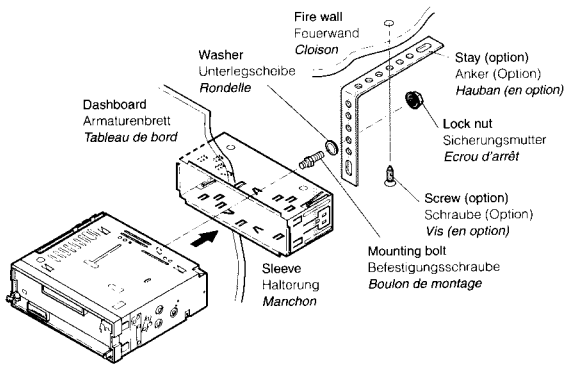

- When installing the unit without using the sleeve
- Beim Einbau des Geräts ohne Halterung
- Lors de l'installation de l'appareil sans utiliser de manchon

In a Toyota for example, first remove the car radio and install the unit in its place. Zum Beispiel in einem Toyota zuerst das Autoradio ausbauen und dann das Gerät an seinem Platz einbauen. Par exemple dans une Toyota, retirer d'abord l'autoradio et installer l'appareil à la place.

- Flat type screws (M5 x 6 mm)*
- Senkkopfschrauben (M5 x 6 mm)*
- Vis à tête plate (M5 x 6 mm)*

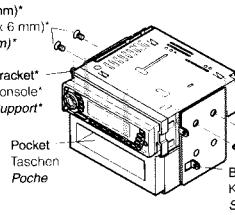

- * Not included with this unit.
- * Nicht Teil dieses Geräts.
- * Non fourni avec cet appareil.

Note: When installing the unit on the mounting bracket, make sure to use the 6 mm-long screws. If longer screws are used, they could damage the unit.

Hinweis: Beim Anbringen des Gerät an der Konsole sicherstellen, daß 6 mm lange Schrauben verwendet werden. Werden längere Schrauben verwendet, können sie das Gerät beschädigen.

Remarque: Lors de l'installation de l'appareil sur le support de montage, s'assurer d'utiliser des vis d'une longueur de 6 mm. Si des vis plus longues sont utilisées, elles peuvent endommager l'appareil.

Removing the unit

- Before removing the unit, release the rear section.
- 1 Remove the control panel.
- 2 Remove the trim plate.
- 3 Insert the 2 handles into the slots, as shown. Then, while gently pulling the handles away from each other, slide out the unit. (Be sure to keep the handles after installing it.)

Ausbau des Geräts

- Vor dem Ausbau des Geräts den hinteren Teil freigegeben.
- 1 Die Schalttafel abnehmen.
- 2 Den Frontrahmen abnehmen.
- 3 Die 2 Griffe in die Schlitze wie gezeigt stecken. Dann die Griffe behutsam auseinander ziehen und das Gerät herausziehen. (Die Griffe nach dem Einbau auf jeden Fall aufbewahren.)

Retrait de l'appareil

- Avant de retirer l'appareil, libérer la section arrière.
- 1 Retirer le panneau de commande.
- 2 Retirer la plaque d'assemblage.
- 3 Introduire les deux poignées dans les fentes, comme montré. Puis, tout en tirant doucement les poignées écartées, faire glisser l'appareil pour le sortir. (S'assurer de conserver les poignées après l'installation de l'appareil.)

1

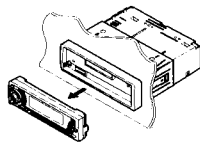

2

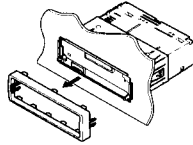

3

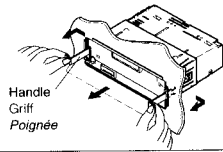

Parts list for installation and connection

The following parts are provided with this unit. After checking them, please set them correctly.

Teilliste für den Einbau und Anschluß

Die folgenden Teile werden zusammen mit diesem Gerät geliefert. Nach ihrer Überprüfung, die Teile richtig einsetzen.

Liste des pièces pour l'installation et raccordement

Les pièces suivantes sont fournies avec cet appareil. Après vérification, veuillez les placer correctement.

Hard case
Etui
Etui de transport

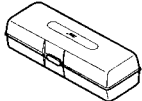

Sleeve
Halterung
Manchon

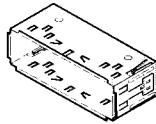

Trim plate
Frontrahmen
Plaque d'assemblage

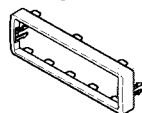

Power cord
Spannungsversorgungskabel
Cordon d'alimentation

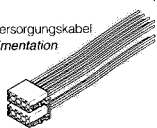

Handles
Griffe
Poignées



Washer (ø5)
Unterlegscheibe(ø5)
Rondelle (ø5)



Lock nut (M5)
Sicherungsmutter (M5)
Ecrou d'arrêt (M5)



Mounting bolt (M5 x 20 mm)
Befestigungsschrauben (M5 x 20 mm)
Boulon de montage (M5 x 20 mm)



Rubber cushion
Gummipuffer
Amortisseur en caoutchouc



Remote controller
Fernbedienung
Télécommande

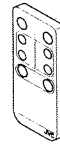

Battery
Batterie
Pile



CR2025

ENGLISH

ELECTRICAL CONNECTIONS

To prevent short circuits, we recommend that you disconnect the battery's negative terminal and make all electrical connections before installing the unit. If you are not sure how to install this unit correctly, have it installed by a qualified technician.

Note:

This unit is designed to operate on 12 volts DC, NEGATIVE ground electrical systems. If your vehicle does not have this system, a voltage inverter is required, which can be purchased at JVC IN-CAR ENTERTAINMENT dealers.

- Replace the fuse with one of the specified rating. If the fuse blows frequently, consult your JVC IN-CAR ENTERTAINMENT dealer.
- If noise is a problem... This unit incorporates a noise filter in the power circuit. However, with some vehicles, clicking or other unwanted noise may occur. If this happens, connect the unit's rear ground terminal (See connection diagram.) to the car's chassis using shorter and thicker cords, such as copper braiding or gauge wire. If noise still persists, consult your JVC IN-CAR ENTERTAINMENT dealer.
- Maximum input of the speakers should be more than 40 watts at the rear and 40 watts at the front, with an impedance of 4 to 8 ohms.
- Be sure to ground this unit to the car's chassis.
- The heat sink becomes very hot after use. Be careful not to touch it when removing this unit.

Heat sink
Abstrahlblech
Dissipateur de chaleur

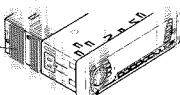

DEUTSCH

ELEKTRISCHE ANSCHLÜSSE

Zur Vermeidung von Kurzschlüssen empfehlen wir, daß Sie den negativen Batterieanschluß abtrennen und alle elektrischen Anschlüsse herstellen, bevor das Gerät eingebaut wird. Sind Sie sich über den richtigen Einbau des Geräts nicht sicher, lassen Sie es von einem qualifizierten Techniker einbauen.

Hinweis:

Dieses Gerät ist für den Betrieb in elektrischen Anlagen mit 12 V Gleichstrom und (-) Erdung ausgelegt. Verfügt Ihr Fahrzeug nicht über diese Anlage, ist ein Spannungsinverter erforderlich, der bei JVC Autoradiohändler erworben werden kann.

- Die Sicherung mit einer der entsprechenden Nennleistung ersetzen. Brennt die Sicherung häufig durch, wenden Sie sich an Ihren JVC Autoradiohändler.
- Sind Störgeräusche ein Problem... Dieses Gerät enthält ein Störfilter im Stromkreis. Bei manchen Fahrzeugen kann jedoch ein Klicken oder andere unerwünschte Störgeräusche auftreten. Sollte das der Fall sein, die hintere Erdungsanschlusssklemme (siehe Schaltplan) des Geräts am Fahrwerk des Fahrzeuges anschließen, dabei kürzere und dickere Kabel wie beispielsweise Kupfergeflecht oder Stahldraht verwenden. Bleibt Störgeräusch bestehen, wenden Sie sich an Ihren JVC Autoradiohändler.
- Maximale Eingangsleistung der Lautsprecher muß höher als 40 W hinten und 40 W vorne sein, mit einer Impedanz von 4 bis 8 Ohm.
- Sicherstellen, daß das Gerät am Fahrwerk geerdet wird.
- Das Abstrahlblech wird nach dem Gebrauch sehr heiß. Beim Ausbau des Geräts darauf achten, das Abstrahlblech nicht zu berühren.

FRANÇAIS

RACCORDEMENTS ELECTRIQUES

Pour éviter tout court-circuit, nous vous recommandons de débrancher la borne négative de la batterie et d'effectuer tous les raccordements électriques avant d'installer l'appareil. Si l'on n'est pas sûr de pouvoir installer correctement cet appareil, le faire installer par un technicien qualifié.

Remarque:

Cet appareil est conçu pour fonctionner sur des sources de courant continu de 12 volts à masse NEGATIVE. Si votre véhicule n'offre pas ce type d'alimentation, il vous faut un convertisseur de tension, que vous pouvez acheter chez un revendeur d'autoradios JVC.

- Remplacer le fusible par un de la valeur précisée. Si le fusible saute souvent, consulter votre revendeur d'autoradios JVC.
- Si le bruit est un problème... Cet appareil incorpore un filtre de bruit dans le circuit d'alimentation. Cependant, avec certains véhicules, quelques claquements ou autres bruits non désirés risquent de se produire. Si cela arrive, raccorder la borne de masse arrière de l'appareil au châssis de la voiture (voir le schéma de raccordement) en utilisant des cordons les plus gros et les plus courts possibles telle qu'une barre de cuivre ou une tresse. Si le bruit persiste, consulter votre revendeur d'autoradios JVC.
- La puissance admissible des haut-parleurs doit être supérieure à 40 watts à l'arrière et à 40 watts l'avant, avec une impédance de 4 à 8 ohms.
- S'assurer de raccorder la mise à la masse de cet appareil au châssis de la voiture.
- Le radiateur devient très chaud après usage. Faire attention de ne pas le toucher en retirant cet appareil.

A Typical Connections / Typische Anschlüsse / Raccordements typiques

Before connecting: Check the wiring in the vehicle carefully. Incorrect connection may cause serious damage to this unit.

1 Connect the colored leads of the power cord to the car battery, speakers and power aerial (if any) in the following sequence.

- (1) Black: ground
- (2) Yellow: to car battery (constant 12V)
- (3) Red: to an accessory terminal
- (4) Others: to speakers
- (5) Blue with white stripe: to power aerial (200mA max.)
- (6) Orange with white stripe: to car light control switch
- (7) Brown: to cellular phone system (For details, refer to the instructions of the cellular phone.)

2 Connect the aerial cord.

3 Finally connect the wiring harness to the unit.

Note: If your vehicle does not have any accessory terminal, move the fuse from the fuse position 1 (initial position) to fuse position 2, and connect the red lead (A7) to the positive (+) battery terminal.
• The yellow lead (A4) is not used in this case.

Vor dem Anschließen: Die Verdrähtung im Fahrzeug sorgfältig überprüfen. Falsche Anschlüsse können ernsthafte Schäden am Gerät hervorrufen.

1 Die farbigen Leitungen des Spannungsversorgungskabels an der Autobatterie, den Lautsprechern und dem Motorantenne (sofern vorhanden) in folgender Reihenfolge anschließen.

- (1) Schwarz: Erdung
- (2) Gelb: an Autobatterie (konstant 12 V)
- (3) Rot: an Zubehörschlußklemme
- (4) Andere: an Lautsprecher
- (5) Blau mit weißem Streifen: an Motorantenne (max. 200 mA)
- (6) Orange mit weißem Streifen: an Autolichtschalter
- (7) Braun: an Mobiltelefon (Weitere Informationen entnehmen Sie bitte der Bedienungsanleitung des Mobiltelefons.)

2 Das Antennenkabel anschließen.

3 Die Kabelbäume am Gerät anschließen.

Hinweis: Verfügt Ihr Fahrzeug nicht über eine Zubehörschlußklemme, die Sicherung von der 1. Sicherungsposition (Erstposition) in die 2. Sicherungsposition versetzen, die rote Leitung (A7) an der (+) Batterieanschlußklemme anschließen.
• Die gelbe Leitung (A4) wird in diesem Fall nicht verwendet.

Avant de commencer la connexion: vérifiez attentivement le câblage du véhicule. Une connexion incorrecte peut endommager sérieusement l'appareil.

1 Connectez les fils de couleur du cordon d'alimentation à la batterie de la voiture, aux enceintes et à l'antenne automatique (s'il y en a une) dans l'ordre suivant.

- (1) Noir: à la masse
- (2) Jaune: à la batterie de la voiture (12V constant)
- (3) Rouge: à la prise accessoire
- (4) Autres: aux enceintes
- (5) Bleu à bandes blanches: à l'antenne automatique (200 mA max.)
- (6) Orange à bandes blanches: à l'interrupteur d'éclairage de la voiture
- (7) Marron: à un système de téléphone cellulaire (Pour les détails, se référer aux instructions du téléphone cellulaire.)

2 Connectez le cordon d'antenne.

3 Finalement, connectez le faisceau de fils à l'appareil.

Remarque: Si votre véhicule ne possède pas de borne accessoire, déplacez le fusible de la position de fusible 1 (position originale) à la position de fusible 2 et connectez le fil rouge (A7) à la borne positive (+) de la batterie.
• Le fil jaune (A4) n'est pas utilisé dans ce cas.

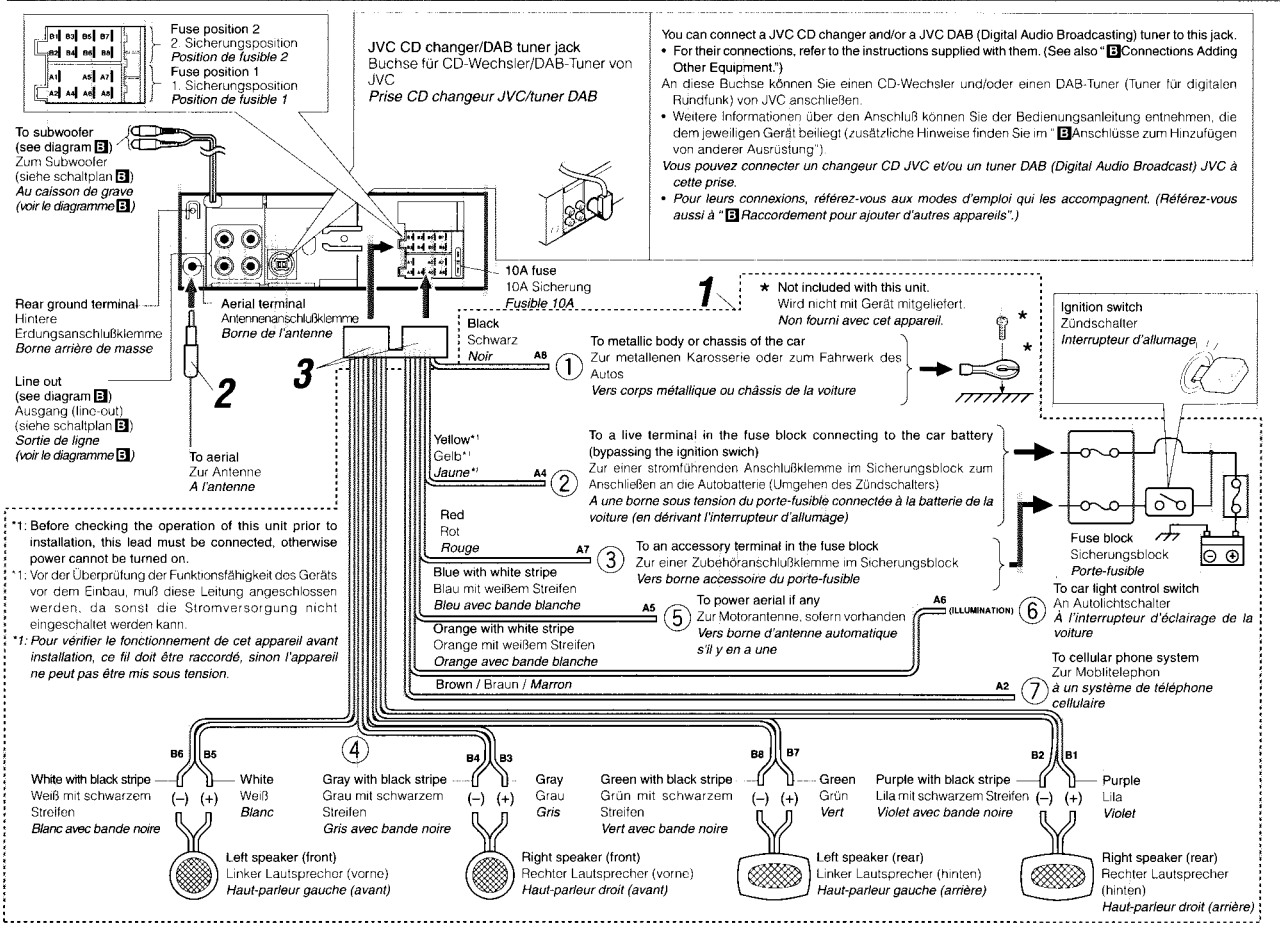

PRECAUTIONS on power supply and speaker connections:

- DO NOT connect the speaker leads of the power cord to the car battery; otherwise, the unit will be seriously damaged.
- Connect the black lead (ground), yellow lead (to car battery, constant 12V), and red lead (to an accessory terminal) correctly.
- BEFORE connecting the speaker leads of the power cord to the speakers, check the speaker wiring in your car.
 - If the speaker wiring in your car is as illustrated in Fig. 1 and Fig. 2 below, DO NOT connect the unit using that original speaker wiring. If you do, the unit will be seriously damaged. Redo the speaker wiring so that you can connect the unit to the speakers as illustrated in Fig. 3.
 - If the speaker wiring in your car is as illustrated in Fig. 3, you can connect the unit using the original speaker wiring in your car.
 - If you are not sure of the speaker wiring of your car, consult your car dealer.

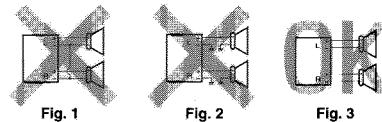

VORSICHTSMASSREGELN beim Anschließen der Stromversorgung und Lautsprecher:

- Die Lautsprecherleitungen des Netzkabels NICHT an der Autobatterie anschließen, da sonst das Gerät schwer beschädigt wird.
- Die schwarze Leitung (Erdung), die gelbe Leitung (zur Autobatterie, konstant 12 V) und die rote Leitung (zur Zubehörschlußklemme) richtig anschließen.
- VOR dem Anschließen der Lautsprecherleitungen des Spannungsversorgungskabels an die Lautsprecher, die Lautsprecherverdrähtung in Ihrem Auto überprüfen.
 - Ist die Lautsprecherverdrähtung wie unten in "Fig. 1" und "Fig. 2" abgebildet, das Gerät NICHT mit der Originalverdrähtung der Lautsprecher anschließen, da sonst das Gerät schwer beschädigt wird. Die Lautsprecherverdrähtung erneuern, so daß Sie das Gerät an den Lautsprechern wie in "Fig. 3" abgebildet anschließen können.
 - Ist die Lautsprecherverdrähtung in Ihrem Auto wie in "Fig. 3" abgebildet, können Sie das Gerät mit der Originalverdrähtung der Lautsprecher in Ihrem Auto anschließen.
 - Sind Sie sich über die Lautsprecherverdrähtung in Ihrem Auto nicht sicher, wenden Sie sich an Ihren Autohändler.

PRECAUTIONS sur l'alimentation et la connexion des enceintes:

- NE CONNECTEZ PAS les fils d'enceintes du cordon d'alimentation à la batterie; sinon, l'appareil serait sérieusement endommagé.
- Connectez correctement le fil noir (à la masse), le fil jaune (à la batterie de la voiture, 12V constant) et le fil rouge (à la prise accessoire).
- AVANT de connecter les fils d'enceintes du cordon d'alimentation aux enceintes, vérifiez le câblage des enceintes de votre voiture.
 - Si le câblage des enceintes de votre voiture est réalisé comme montré sur la Fig. 1 ou Fig. 2 ci-dessous, NE CONNECTEZ PAS l'appareil en utilisant ce câblage original d'enceintes. Si vous le faites, l'appareil sera sérieusement endommagé. Recommencez le câblage des enceintes de façon que vous puissiez connecter l'appareil aux enceintes comme montré sur la Fig. 3.
 - Si le câblage des enceintes de votre voiture est comme montré sur la Fig. 3, vous pouvez connecter l'appareil en utilisant ce câblage original d'enceintes pour votre voiture.
 - Si vous n'êtes pas sûrs du câblage d'enceintes de votre voiture, consultez le concessionnaire de votre voiture.

Connecting the leads / Anschließen der Leitungen / Raccordement des fils

Twist the core wires when connecting.
Die Kerndrähte beim Anschließen verdrehen.
Torsader les âmes des fils en les raccordant.

Solder the core wires to connect them securely.
Die Kerndrähte anlöten, um sie fest anzuschließen.
Souder les âmes des fils pour les raccorder entre eux de façon sûre.

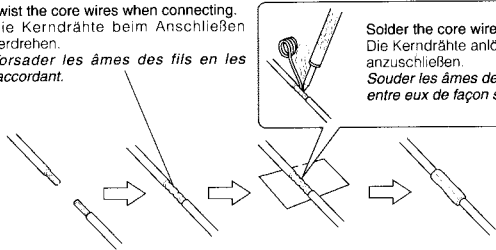

CAUTION / VORSICHT/ PRECAUTION:

- To prevent short-circuit, cover the terminals of the UNUSED leads with insulating tape.
- Zur Vermeidung eines Kurzschlusses die Anschlußklemmen der NICHT VERWENDETEN Leitungen mit Isolierklebeband umwickeln.
- Pour éviter les court-circuits, couvrir les bornes des fils qui ne sont PAS utilisés avec de la bande isolante

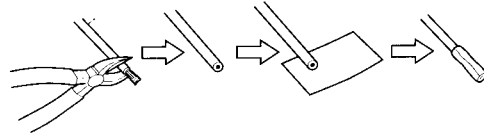

B Connections Adding Other Equipment / Anschlüsse zum Hinzufügen von anderer Ausrüstung / Raccordement pour ajouter d'autres appareils

You can connect an amplifier and other equipment to upgrade your car stereo system.

- Connect the remote lead (blue with white stripe) to the remote lead of the other equipment so that it can be controlled through this unit.
- For amplifier only:
 - Connect this unit's line-out terminals to the amplifier's line-in terminals.
 - Disconnect the speakers from this unit, connect them to the amplifier. Leave the speaker leads of this unit unused. (Cover the terminals of these unused leads with insulating tape, as illustrated above.)
- For subwoofer only:
 - Connect this unit's SUB WOOFER plugs to the amplifier's line-in jacks.

- Sie können einen Verstärker oder ein anderes Gerät anschließen, um Ihre Autostereoanlage zu erweitern.
- Schließen Sie das Fernbedienungskabel (blau mit weißem Streifen) an das Fernbedienungskabel des anderen Geräts an, so daß es über dieses Gerät gesteuert werden kann.
 - Nur für den Verstärker:
 - Die Anschlußklemmen am Ausgang (line-out) dieses Gerät an den Anschlußklemmen des Ausgangs (line-out) des Verstärkers anschließen.
 - Die Lautsprecher von diesem Gerät abtrennen und am Verstärker anschließen. Die Lautsprecherleitungen dieses Geräts unbenutzt lassen. (Die Anschlußklemmen dieser nicht verwendeten Leitungen mit Isolierband umwickeln, siehe Abb. oben.)
 - Nur für den Subwoofer:
 - Die Stecker SUB WOOFER des Geräts an die Line-In-Buchsen am Verstärker anschließen.

Vous pouvez connecter un amplificateur ou autre appareil pour améliorer votre système autoradio.

- Connectez le fil de commande à distance (bleu avec bande blanche) au fil de commande à distance de l'autre appareil de façon qu'il puisse être commandé via cet appareil.
- Pour l'amplificateur seulement:
 - Raccorder les bornes de sortie ligne de cet appareil aux bornes d'entrée ligne de l'amplificateur.
 - Déconnectez les enceintes de cet appareil et connectez-les à l'amplificateur. Laissez les fils d'enceintes de cet appareil inutilisés. (Recouvrir les extrémités de ces fils inutilisés avec de la bande isolante comme montré ci-dessus.)
- Pour le caisson de grave seulement:
 - Connectez les fiches SUBWOOFER de cet appareil aux prises d'entrée de ligne de l'amplificateur.

Amplifier / Verstärker / Amplificateur

The line output level of this unit is kept high to maintain the hi-fi sounds reproduced from this unit.
When connecting an external amplifier to this unit, turn down the gain control on the external amplifier to obtain the best performance from this unit.

Der Ausgangspegel dieses Geräts wird auf einem hohen Wert gehalten, um den Hi-Fi-Klang zu unterstützen, den dieses Gerät reproduziert.
Wenn Sie einen externen Verstärker an dieses Gerät anschließen, stellen Sie den Verstärkungsregler des externen Verstärkers herunter, um die bestmögliche Leistung dieses Geräts zu erzielen.

Le niveau de sortie de ligne de cet appareil est maintenu à un niveau élevé pour maintenir une qualité Hi-Fi pour les sons reproduits par cet appareil.
Lors de la connexion d'un amplificateur extérieur à cet appareil, diminuez le réglage du gain sur l'amplificateur extérieur pour obtenir les meilleures performances de cet appareil.

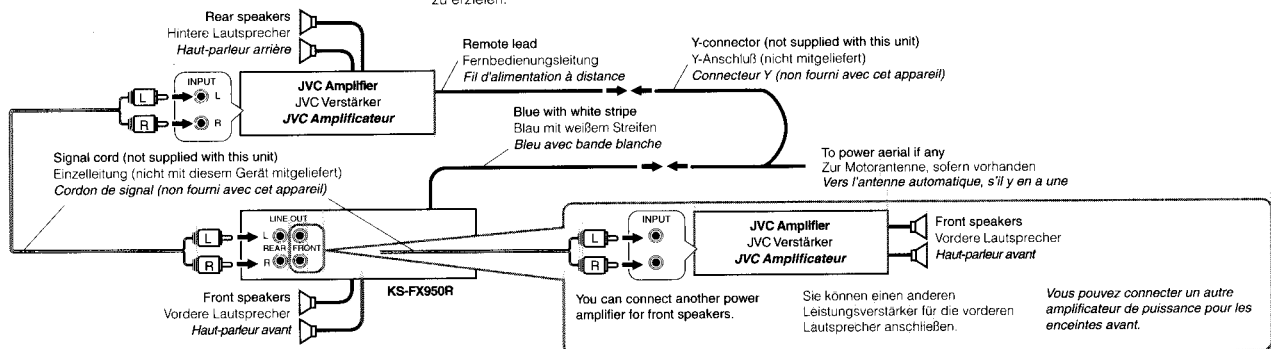

CD changer and DAB tuner / CD-Wechsler und DAB-Tuner / Changeur CD et tuner DAB

You can connect a JVC CD changer and/or a JVC DAB (Digital Audio Broadcasting) tuner.

- For their connections, refer to the instructions supplied with them.

Sie können einen CD-Wechsler und/oder einen DAB-Tuner (Tuner für digitalen Rundfunk) von JVC anschließen.

- Weitere Informationen über den Anschluß können Sie der Bedienungsanleitung entnehmen, die dem jeweiligen Gerät beiliegt.

Vous pouvez connecter un changeur CD JVC et/ou un tuner DAB (Digital Audio Broadcast) JVC.

- Pour leurs connexions, référez-vous aux modes d'emploi qui les accompagnent.

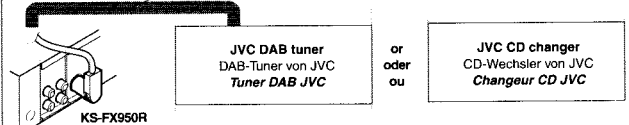
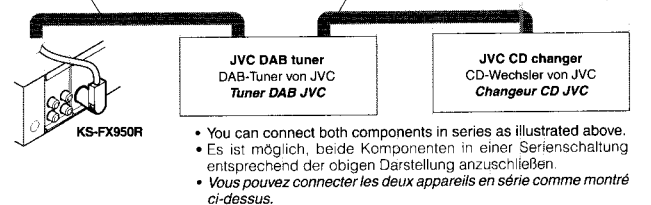

- CAUTION / VORSICHT/ PRECAUTION:**
- Before connecting the CD changer and/or the DAB tuner, make sure that the unit is turned off.
 - Bevor Sie den CD-Wechsler und/oder den DAB-Tuner anschließen, vergewissern Sie sich, daß das Gerät ausgeschaltet ist.
 - Avant de connecter le changeur CD et/ou le tuner DAB, s'assurer que l'unité est éteinte.

Subwoofer / Subwoofer / Caisson de grave

You can connect a subwoofer to reinforce the bass.

- For their connections, refer to the instructions supplied with your subwoofer.

Sie können einen Subwoofer anschließen, um den Baß zu verstärken.

- Weitere Informationen über den Anschluß entnehmen Sie bitte der Bedienungsanleitung des Subwoofers.

Vous pouvez connecter un caisson de grave pour renforcer les graves.

- Pour la connexion, référez-vous aux instructions fournies avec le caisson de grave.

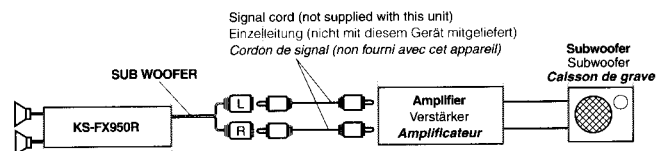
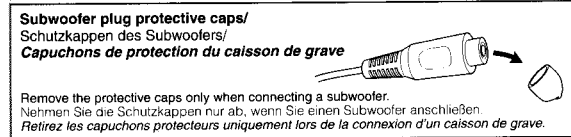

Disassembly method

■ Removing the front panel unit

- 1. Press the Eject button to open the front panel unit (See fig 1)
- 2. Push and open the right and left open/close shaft arms outward to remove the shaft. (See fig 2)
- 3. Remove the front panel unit from the same side as the shaft was removed.

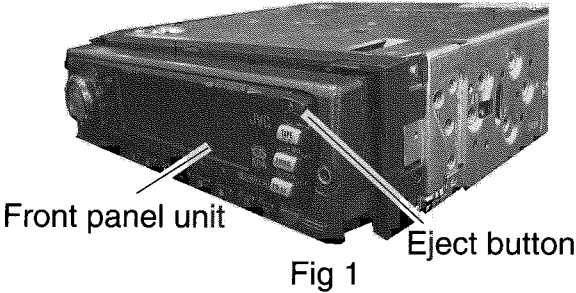

■ Removing the front chassis assembly

- 1. Remove the front panel unit.
- 2. Remove the two screws **A** securing the front chassis assembly. (See fig 3)
- 3. Remove the four ribs **a** securing the front chassis assembly to the chassis. (See fig 4)

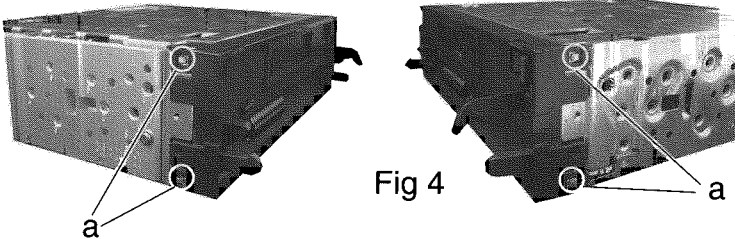
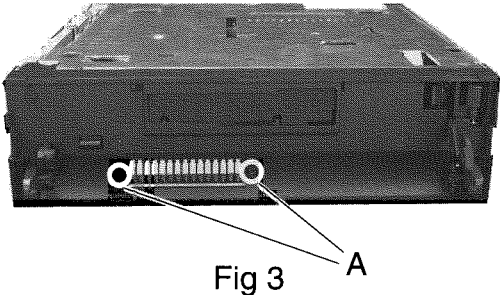
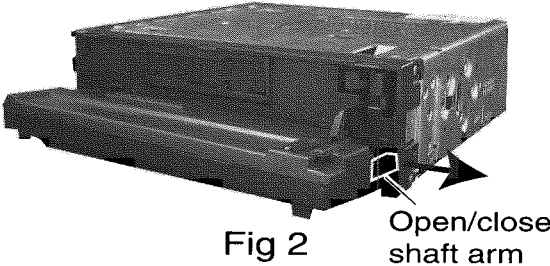

■ Removing the bottom cover assembly

Turn the unit upside down, then insert and turn to **b** the screwdriver to remove the bottom cover. (See fig 5)

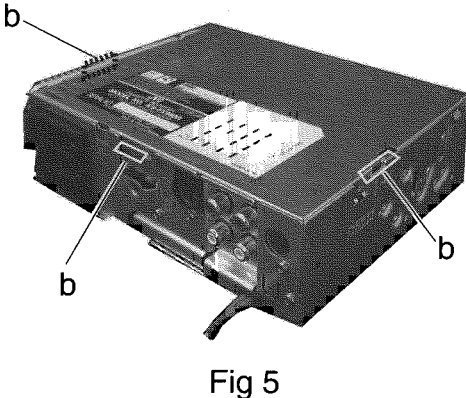

■ **Removing the main board(wiht rear panel)**
(See fig6.7)

- 1.Remove two screws **E** retaining the rear panel to the chassis
- 2.Remove one screw **C** retaining the IC to the heat sink.
- 3.Remove two screws **D** retaining the main bord.
- 4.Lift up the main board to remove it. At this time,remove the connector CP501 connecting the main board and Cassette mechanism.
- 5.Remove two screws **B** to remove the heat sink.

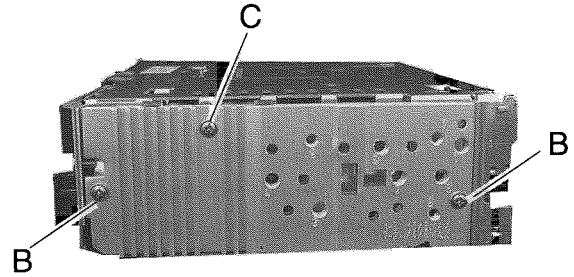

Fig 6

■ **Removing the rear brackt (See fig7)**

- 1.Remove one screw **I** to remove the IC bracket.
- 2.Remove one screw **F** to remove the line-out jack.
- 3.Remove one screw **G** to remove the antenna jack.
- 4.Remove one screw **H** to remove the connector.

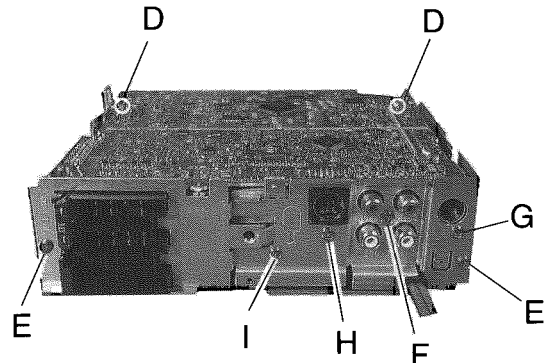

Fig 7

■ **Cassette mechanism assembly (See fig8)**

Remove four mechanism mounting screws **J** retaining the top cover.

■ **Front panel unit (See fig9)**

Remove six screws **K** retaining the rear cover.

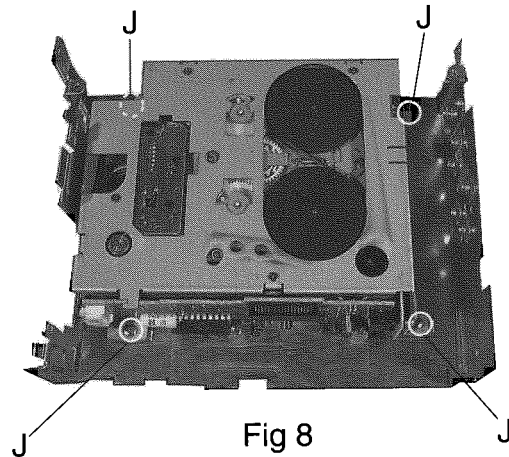

Fig 8

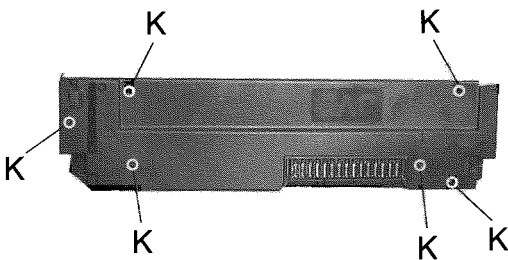

Fig 9

" Cassette Mechanism Sections "

■ Removing the Head Relay Board (See Fig. 1)

1. Resolder the lead wires of the loading motor at the two positions shown (RED, BLACK).
2. Resolder the lead wires of the head at the three positions shown (RED, YELLOW, BLACK).
3. Remove the three screws A securing the head relay board.
4. Shift the interlocking section a securing the head relay board in the direction shown by the arrow 1. to remove the printed circuit board.

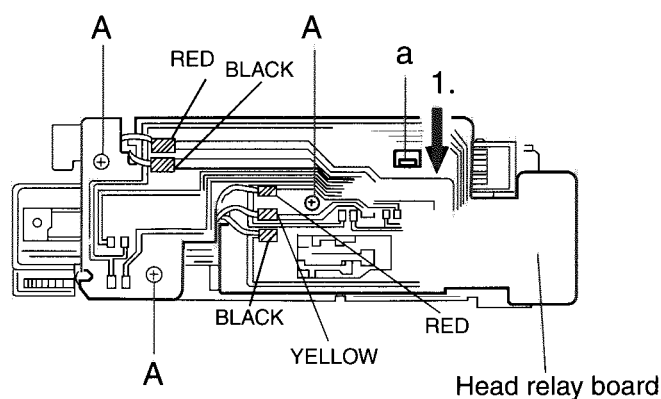

Fig. 1

■ Removing the Load Arm Assembly (See Fig. 2)

1. Using tweezers, detach the mylar washer b securing the load arm assembly and pull out the load arm assembly.

Note : When reassembling, be sure to use a new mylar washer.

2. Shift the load arm assembly counterclockwise.
3. Remove the load arm assembly from the catch (K).

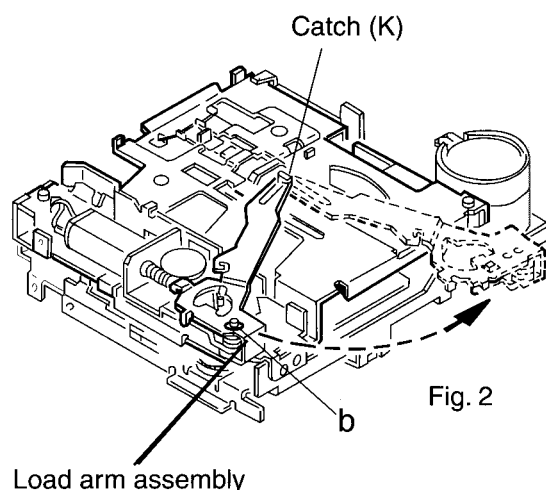

Fig. 2

■ Removing the Cassette Holder and Holder Arm Assembly (See Fig. 3)

1. Removing the head relay board.
2. Removing the load arm assembly.
3. Apply DC 6V to the lead wire of the loading motor assembly and turn the load gear assembly to the position shown in Fig. 3.
4. Remove the screw B securing the cassette holder and holder arm assembly.
5. Shift the cassette holder and the holder arm assembly in the direction shown by the arrow 2. and remove them from the interlocking section c of the sub chassis assembly.

■ Removing the Sub Chassis Assembly (See Fig. 3)

1. Removing the head relay board.
2. Removing the load arm assembly.
3. Removing the cassette holder and holder arm assembly.
4. Remove the cassette holder and holder arm assembly.
5. Remove the two screws (C . D) securing the sub chassis assembly.

Note : When removing the sub chassis assembly, the mode gear may become detached. In this case, set it back to the original position.

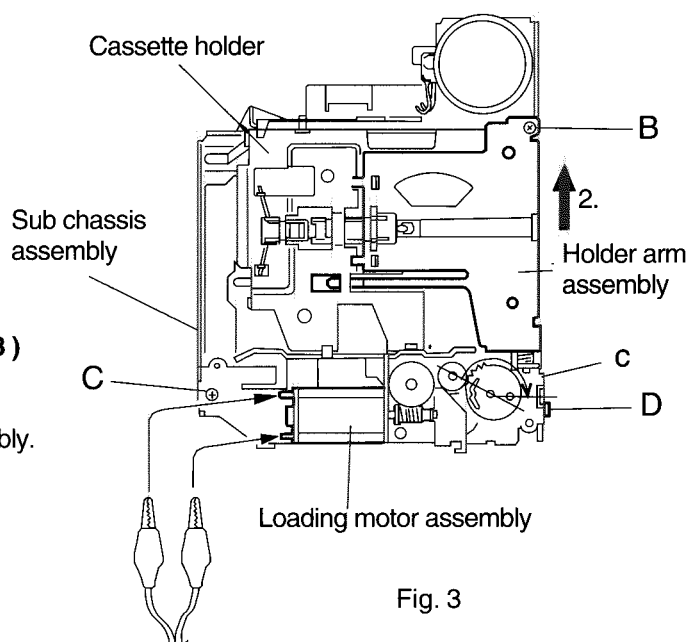
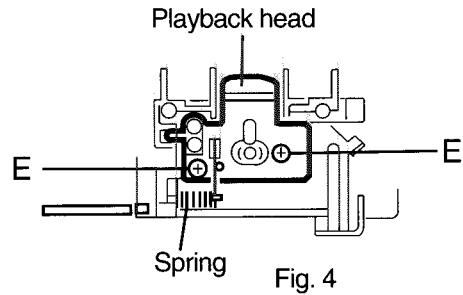

Fig. 3

■ Removing the Playback Head (See Fig. 4)

1. Removing the head relay board.
2. Removing the load arm assembly.
3. Removing the cassette holder and holder arm assembly.
4. Removing the sub chassis assembly.
5. Disengage the spring holding the playback head down.
6. Remove the two screws E securing the playback head.



■ Removing the Pinch Roller Assembly (See Fig. 5,6)

1. Removing the head relay board.
2. Removing the load arm assembly.
3. Removing the cassette holder and holder arm assembly.
4. Removing the sub chassis assembly.
5. Detach the mylar washers d at the two positions securing the right and left pinch roller assemblies.

Note : When reassembling, be sure to use new mylar washers.
Also, make sure that grease is not adhering to the pinch rollers.

6. Pull out the pinch rollers.

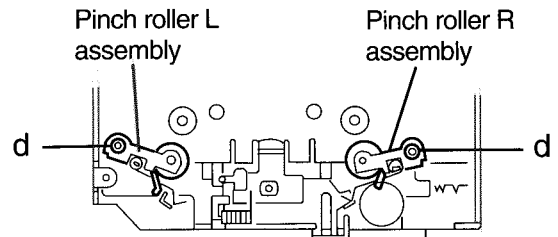

Fig. 5

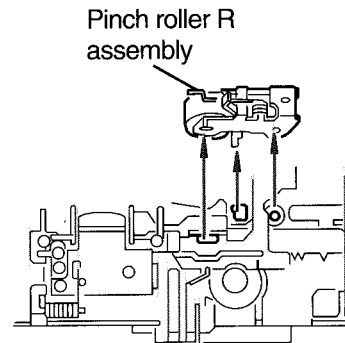

Fig. 6

■ Removing the Reel Disk Assembly (See Fig. 7)

1. Removing the head relay board.
2. Removing the load arm assembly.
3. Removing the cassette holder and holder arm assembly.
4. Removing the sub chassis assembly.
5. Detach the mylar washer e from the tip by first pressing down the reel driver to expose it.

Note : When reassembling, be sure to use a new mylar washer.

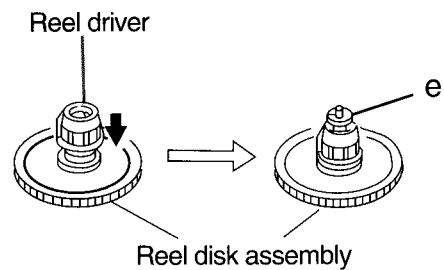

Fig. 7

■ Removing the Head Plate (See Fig. 8,9)

1. Removing the head relay board.
 2. Removing the load arm assembly.
 3. Removing the cassette holder and holder arm assembly.
 4. Removing the sub chassis assembly.
 5. Removing the left and right pinch roller assembly.
 6. From the rear of the head plate, detach the mylar washer *f* and washer pressing the forward/reverse plate down.
 7. Remove the two screws *F* fixing the metal detection lever and removal spring as shown in Fig. 8.
 8. Remove the head plate.
 9. Pull out the mode gear.
- Note : When installing the mode gear, set it to the arrow mark.

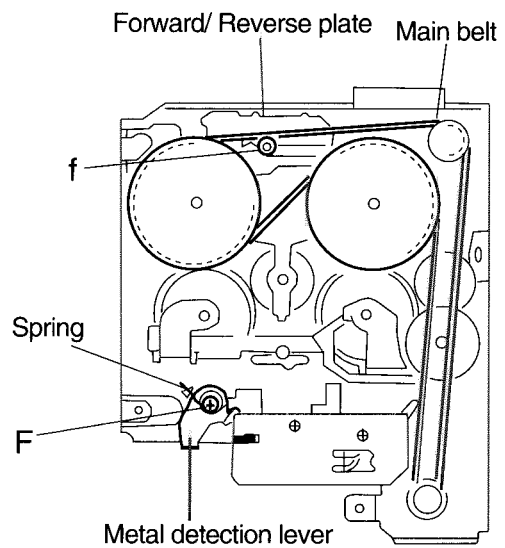

Fig. 8

■ Removing the Flywheel Assembly (See Fig. 9)

1. Removing the head relay board.
2. Removing the load arm assembly.
3. Removing the cassette holder and holder arm assembly.
4. Removing the sub chassis assembly.
5. Removing the Head Plate.
6. Disengage the main belt from the flywheel assembly.
7. Remove the E.washer *g* at the two positions which secure the capstan shaft away from the surface.
8. Pull out the flywheel assembly from the rear.

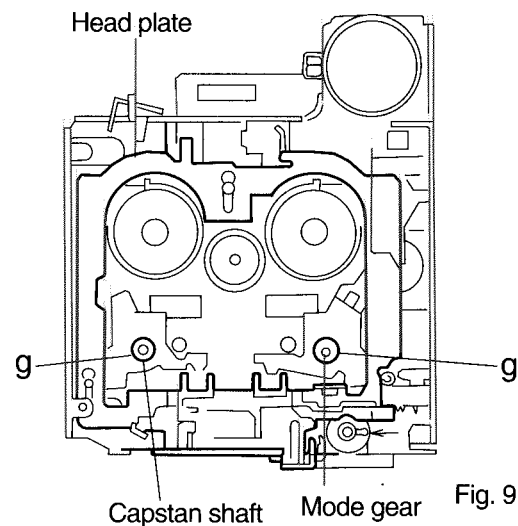

Fig. 9

■ Removing the Reel Disk Board (See Fig. 10)

1. Removing the head relay board.
2. Removing the load arm assembly.
3. Removing the cassette holder and holder arm assembly.
4. Removing the sub chassis assembly.
5. Straighten the curved tab *h* from the tip by first pressing down the reel feather to expose it.
6. Remove the two screws *G* fixing the reel disk board.
7. Remove the reel disk board.

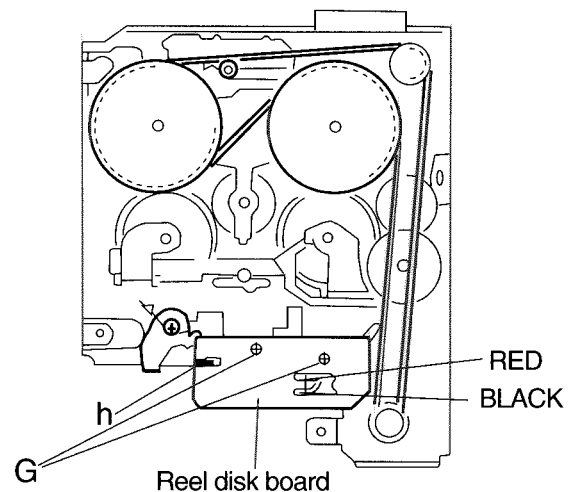

Fig. 10

■ Removing the Loading Motor Assembly (See Fig. 11)

1. Removing the head relay board.
2. Removing the load arm assembly.
3. Remove the mylar washer *i* fixing the worm gear.
 Note : When reassembling, be sure to use a new mylar washer.
4. Remove the one screw *H* fixing the loading motor assembly.
5. Remove the two screws *I* fixing the motor bracket.

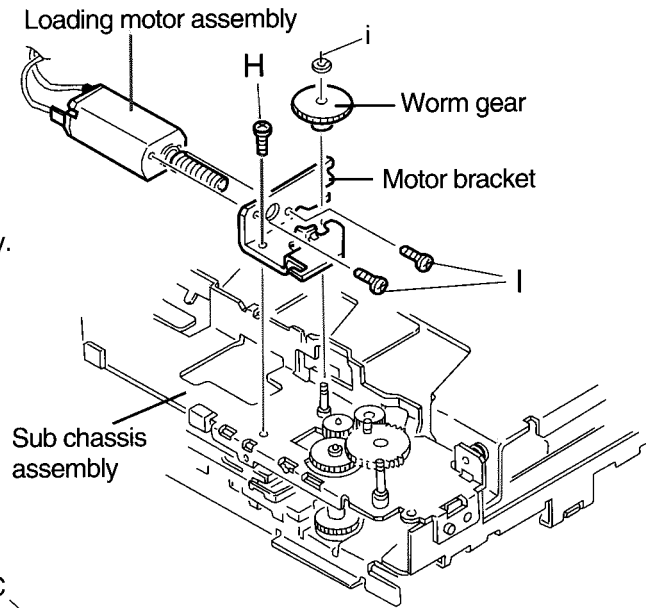

Fig. 11

■ Removing the Flywheel Assembly (See Fig. 12)

1. Insert the mode gear into the sub chassis assembly.
2. Install the sub chassis assembly and secure it with the two screws *C* and *D* as shown in.
 Note : The set arm assembly and the mode gear should be positioned as shown in Fig. 12.

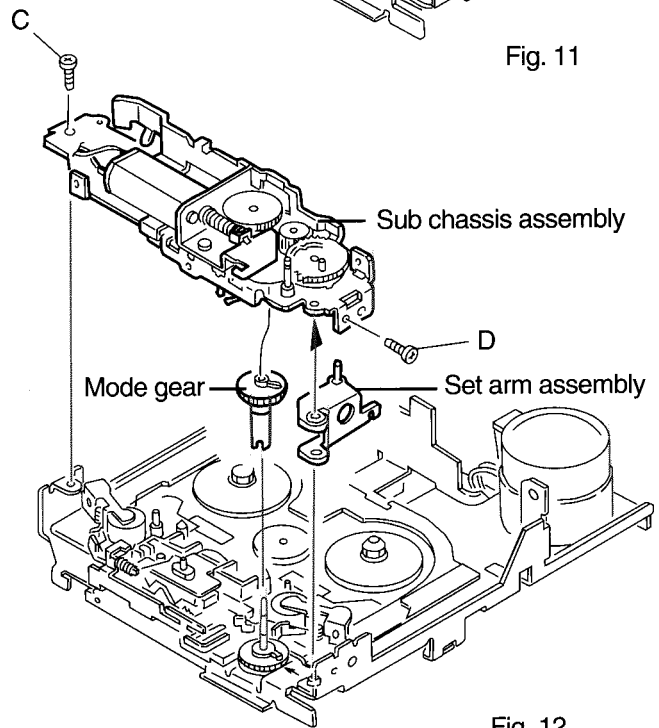

Fig. 12

3. Attach the cassette holder as shown in Fig. 13.
 In the case, first pass the tab of the section *j* through the mechanism *k* , then attach the cassette holder in the direction shown by arrow.

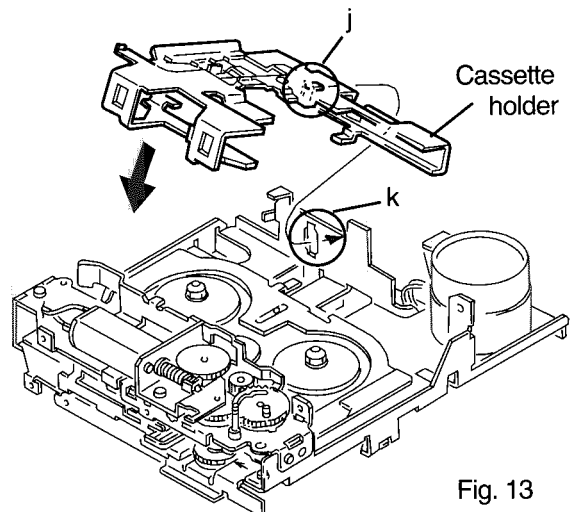
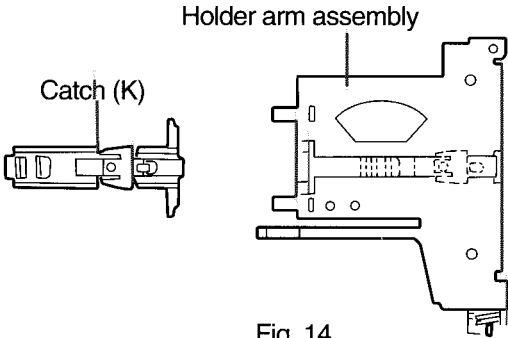
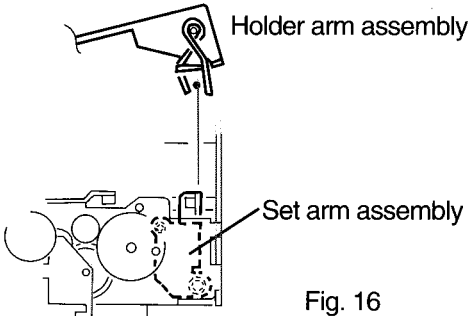
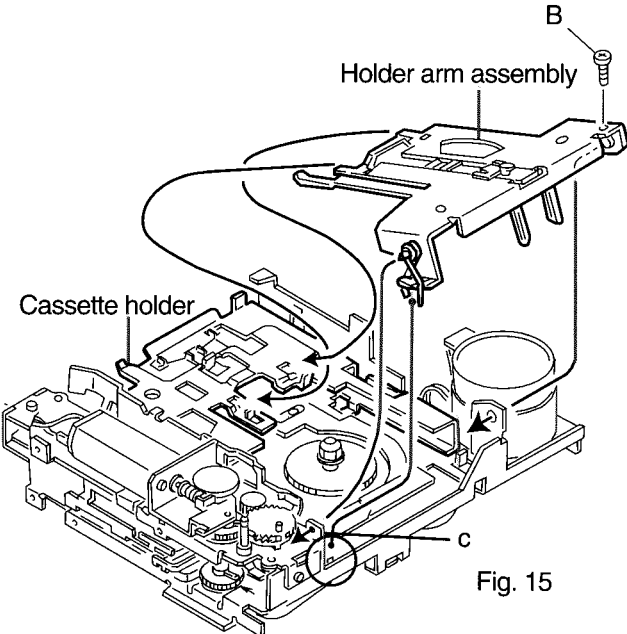

Fig. 13

4. Set the catch (K) to the holder arm assembly as shown in Fig. 14.



- 5. While attaching the holder arm assembly to the cassette holder, insert the shaft of the holder arm assembly into the interlocking section c of the sub chassis assembly as shown in Fig. 15.
- 6. Install the spring attached to the holder arm assembly shaft over the set arm assembly as shown in Fig. 16.
- 7. After the holder arm assembly is installed, secure it with the screw B (See Fig. 15)



- 8. After the installation , apply DC6V to the lead wires of the loading motor assembly to locate the load gear assembly as shown in Fig. 17.
- 9. Install the load arm assembly.
- 10. Install the head relay board..

Note : Install it so that the slide switch lever of the head relay board is set in the printed circuit board stay hook of the sub chassis assembly. (See Fig. 18)

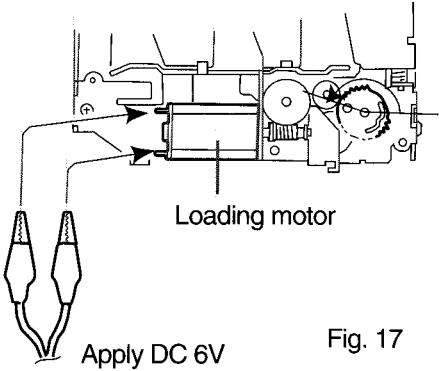
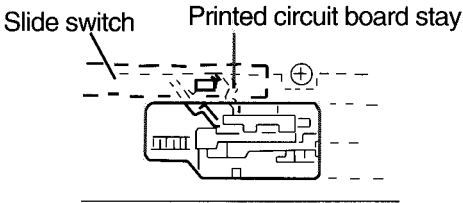

11. Solder the loading motor and head lead wires to the head relay board, respectively. (See Fig. 19)

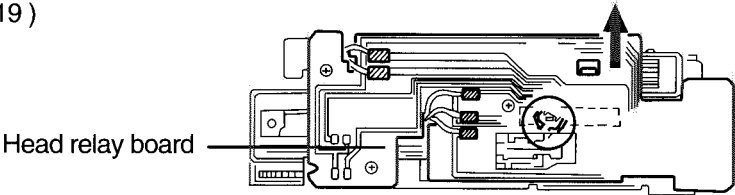

Adjustment method

■ Test Instruments required for adjustment

1. Digital oscilloscope(100MHz)
2. Frequency Counter meter
3. Electric voltmeter
4. Wow & flutter meter
5. Test Tapes
 VT724 ----- for DOLBY level measurement
 VT739 ----- For playback frequency measurement
 VT712 ---- For wow flutter & tape speed measurement
 VT703 ----- For head azimuth measurement
6. Torque gauge ----- Cassette type for CTG-N
 (mechanism adjustment)

■ Measuring conditions(Amplifier section)

- Power supply voltage ----- DC14.4V(10.5~16V)
 Load impedance ----- 4 Ω (2Speakers connection)
 Line out ----- 20k Ω

■ Standard volume position

- Balance and Bass, Treble volume .Fader
 :Center(Indication"0")
 Loudness, Dolby NR, Sound, Cruise:Off
 Volume position is about 2V at speaker output with
 following conditions. Playback the test tape VT721.

- | | |
|----------------|--|
| AM mode | 999kHz/62dB, INT/400Hz, 30%
modulation signal on receiving. |
| FM mono mode | 97.9MHz/66dB, INT/400Hz, 22.5kHz
deviation pilot off mono |
| FM stereo mode | 1kHz, 67.5kHz dev. pilot 7.5kHz dev. |
| Output level | 0dB(1 μV, 50 Ω / open terminal) |

■ Tuner section

BAND STEP

- FM : 100kHz (Seek), 50kHz (Manual)
 AM : 9kHz step

■ Preset Memory Initialization

Band	Preset Memory					
	M1	M2	M3	M4	M5	M6
FM(MHz)	87.5	89.9	97.9	105.9	108.0	87.5
AM(kHz)	153	216	603	999	1404	1620

DUMMY LOAD

Exclusive dummy load should be used for AM and FM dummy load, there is a loss of 6dB between SSG output and antenna input. The loss of 6dB need not be considered since direct reading of figures are applied in this working standard.

■ Arrangement of Adjusting

Cassette Mechanism Section

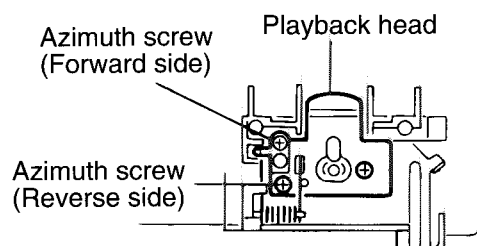
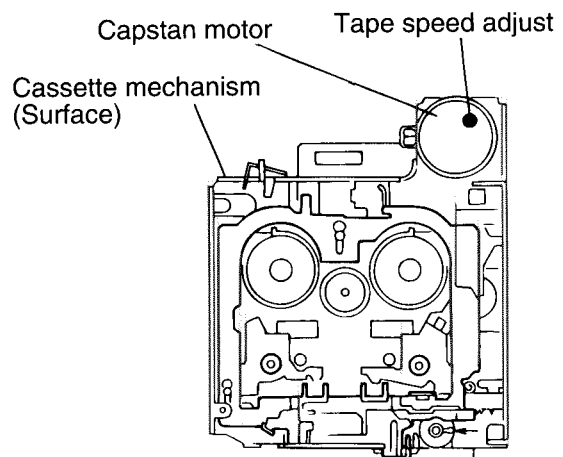

■ **Arrangement of adjusting**

Head amplifier board section

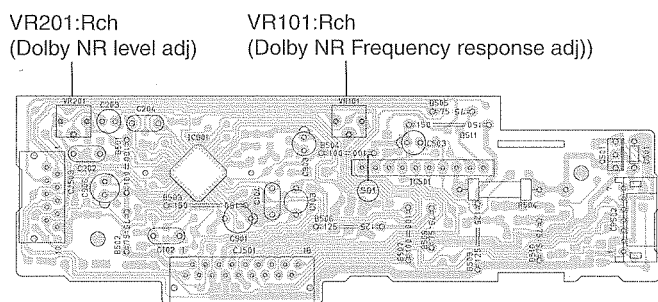

■ **Information for using a Car Stereo service jig (for adjustment and checking)**

- We are advancing efforts to make our extension cords common for all Car Stereo products. Please use this type of extension cord as follows.
- As a U-shape type top cover is employed, this type of extension cord is needed to check operation of the mechanism assembly after disassembly.
- Extension cords

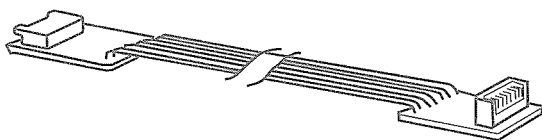

EXT-KSRT002-18P(18 pin extension cord)

For connection between mechanism assembly and main board assembly.

Check for mechanism-driving section such as motor, etc.

- Disassembly method. (Refer to method to remove main parts)
 1. Remove the bottom cover.
 2. Remove the front panel assembly.
 3. Remove the top cover. (Remove the screws at each side of heat sink and rear panel)
 4. Install the front panel (whose assembly was removed in step 2) to the main unit.
 5. Confirm that current is being carried by connecting an extension cord jig.

● Connection diagram

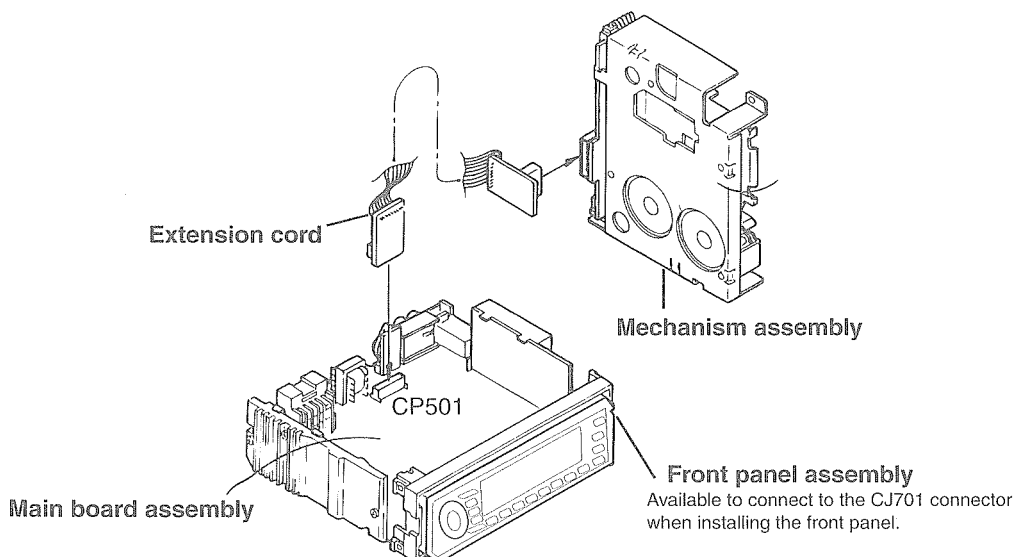

■ Head Amplifier Sections

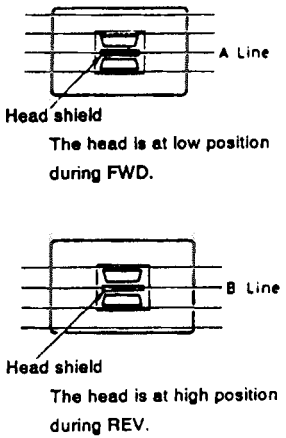
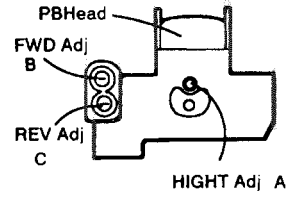
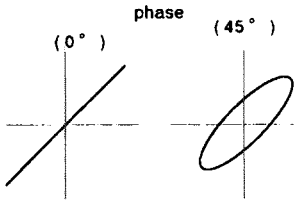
Item	Conditions	Adjustment and Confirmation methods	S.Values	Adjust
<p>1. Head azimuth adjustment</p>	<p>Test tape: SCC – 1659 VT703(10kHz)</p>	<p>◆ Head height adjustment ※ Adjust the azimuth directly. When you adjust the height using a mirror tape, remove the cassette housing from the mechanism chassis. After installing the cassette housing, perform the azimuth adjustment.</p> <ol style="list-style-type: none"> 1. Load the SCC – 1659 mirror tape. Adjust with height adjustment screw A and azimuth adjustment screw B so that line A of the mirror tape runs in the center between Lch and Rch in the reverse play mode. 2. After switching from REV to FWD then to REV, check that the head position set in procedure 1 is not changed. (If the position has shifted, adjust again and check.) 3. Adjust with azimuth adjustment screw B so that line B of the mirror tape runs in the center between Lch and Rch in the forward play mode. <p>◆ Head azimuth adjustment</p> <ol style="list-style-type: none"> 1. Load VTT724 (VT724) (1 kHz) and play it back in the reverse play mode. Set the Rch output level to max. 2. Load VTT703 (VT703) (10 kHz) and play it back in the forward play mode. Adjust the Rch and Lch output levels to max. with azimuth adjustment screw B. In this case, the phase difference should be within 45° 3. Engage the reverse mode and adjust the output level to max. with azimuth adjustment screw C. (The phase difference should be 45° or more.) 4. When switching between forward and reverse modes, the difference between channels should be within 3 dB. (Between FWD L and R, REV L and R) 5. When VTT721 (VT721) (315 Hz) is played back, the level difference between channels should be within 1.5 dB. 	<p>S.Values</p>  <p>Adjust</p> <p>Output level: Maximum</p>  <p>phase (0°) (45°)</p> 	
<p>2. Tape speed and wow flutter confirmation</p>	<p>Test tape:VTT712 (3kHz)</p>	<ol style="list-style-type: none"> 1. Check to see if the reading of the F. counter/wow flutter meter is within 3015~3045(FWD/REV), and less than 0.35% (JIS RMS) . 2. In case of out of specification, adjust the motor with a built-in volume resistor. 	<p>Tape speed: 3015 ~3045Hz Wow flutter:less than0.35%</p>	<p>Built-in volume resistor</p>
<p>Adjusting the frequency compare level</p>	<p>Tast tape: VTT739 Output terminal for measurement: TP101 (L) TP201 (R)</p>	<ol style="list-style-type: none"> 1. Playback the test tape VTT739. 2. Adjust the VR102 (L) and VR202 (R) so that the Dolby NR frequency compare level is 0 ± 4dB (12.5kHz against 1kHz by TP101 (L), TP201 (R). 	<p>12.5kHz against 1kHz : 0dB ± 4dB</p>	<p>LcH : VR102 RcH : VR202</p>
<p>Adjusting the Dolby NR level</p>	<p>Tast tape: VTT724 Output terminal for measurement: TP101 (L) TP201 (R)</p>	<ol style="list-style-type: none"> 1. Playback the test tape VTT724. 2. Adjust the VR101 (L) and VR201 (R) so that the Dolby NR level is 27.5mV ± 0.5dB by TP101 (L), TP201 (R). 	<p>27.5mV ± 0.5dB</p>	<p>VR101 (L) VR201 (R)</p>

The tuner section is of an adjustment-freedesign. In case the tuner is in trouble, replace the tuner pack.

Description of major ICs

■ BA3220FV-X(IC121/IC221) : Line Out Amp

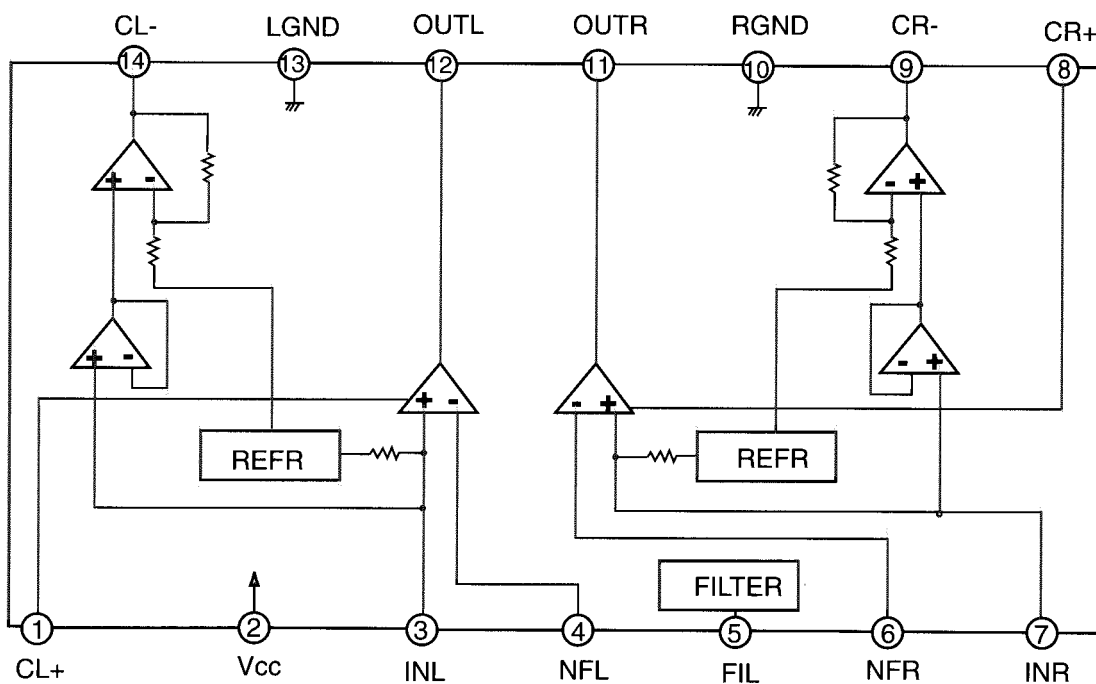
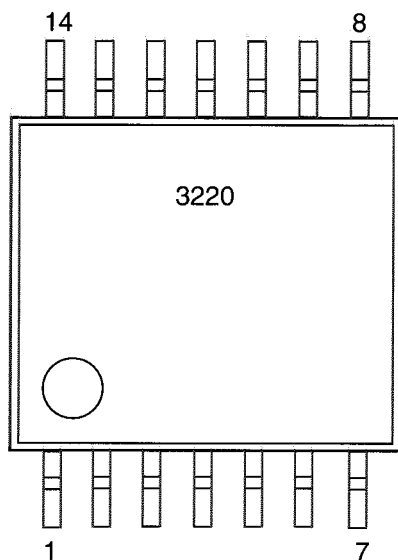

■ UPD178018AGC-543 (IC701) : MAIN SYSTEM CONTROL CPU

Pin No.	Port Name	I/O	Descriptions
1	KEY 0	I	Key input 0
2	KEY 1	I	Key input 1
3	KEY 2	I	Key input 2
4	LEVEL	I	Level meter input
5	SM	I	S.meter level input
6	SQ	I	S.Quality level input
7	LCD-CE	O	CE output to LCD driver
8	LCD-DA	O	Data output to LCD driver
9	LCD-SCK	O	Clock output to LCD driver
10	BUS-I/O	I	I/O selector output for J-BUS, H : OUT, L: INPUT
11	INLOCK	O	Tuner lock detection output Lock : H
12	BUS-SI	I	J-BUS Data input
13	BUS-SO	O	J-BUS Data output
14	BUS-SCK	I/O	J-BUS Clock in/output
15	SW-CONT	O	Sub woofer .PWM output for level setting
16	NC	O	Non connect
17	NC	O	Non connect
18	SW-MUTE	O	Subwoofer volume value 00.and mute L : output
19	NC	O	Non connect
20	AMP-KILL	O	AMP :OFF H:output
21	GNDPORT	-	Port GND
22	VDDPORT	-	Port Vdd
23	NC	O	Non connect
24	AFCK	O	AF check output, L: AF check
25	MONO	O	Monaural on /off selecting output, H:mono on
26	AM/FM	O	FM/AM switching output L : FM H : AM
27	SEEK/STP	O	Auto seek /stop selecting output, H: Seek, L:Stop
28	CRUISE	I	Pulse signal input port for Cruise control
29	IFC	I	FM/AM midle frequency counter input
30	VDDPLL	-	PLL Vdd
31	OSC	I	FM/AM limited generator frequency input
32	NC	I	None connect
33	GNDPLL	-	PLL GND
34	AMEO	O	AM error out output
35	FMEO	O	FM error out output
36	IC	-	GND
37	SD/ST	I	Station detector, Stereo signal input, H:Find Station, L:Stereo
38	STAGE0	I	Pull up
39	LOCAL	O	Local ON / OFF switching output H : on
40	F/R	I	FWE.REV running direction switch signal input. L : FWD L : REV

■ UPD178018AGC-543 (IC701) : MAIN SYSTEM CONTROL CPU

Pin No.	Port Name	I/O	Descriptions
41	MSIN	I	MS input
42	DOLBY	O	Dolby on "H" output
43	FF/REW	O	Output for input signal level switching for MS L:FF.REW H:PLAY
44	TAPE IN	I	Cassette in detection input H : cassette in L : cassette out
45	I2C-CLK	O	I2C information clock output
46	I2C-DAO	O	I2C information data output
47	I2C-DAI	I	I2C information clock input
48	MOTOR	O	Main motor output H : motor works
49	MODE	I	Mechanism mode position detection input
50	STANDBY	I	Standby position detection input H : eject side L : operation side
51	SUBMO-	O	Sub-motor clock direction drive output
52	SUBMO+	O	Sub-motor clock opposite direction drive output
53	T-END	I	Tape end detection input H : PLAY
54	KICK	O	Kick output L : kick
55	TPF CNT1	O	Sub-woofer cutting off frequency control output
56	LPF CNT2	O	Sub-woofer cutting off frequency control output
57	BEE	O	BEE, ON/OFF switching H : ON
58	OPEN	I	Door open detection input H : Open
59	BEEP	O	Touch tone output
60	MUTE	O	Mute output , L : mute on
61	POWER	O	Power ON /OFF switching output , H : power on
62	TEL-MUTE	I	Telephone mute signal detection input
63	DIM-IN	I	Dimmer signal detection input L : dimmer
64	DIM-OUT	O	Dimmer control output , Dimmer off L output
65	VOL-1	I	Rotary volume signal 1 input Power save : L
66	VOL-2	I	Rotary volume signal 2 input
67	PS1	I	Power save 1 Working together ACC Power save : L
68	PS2	I	Power save 2, Working together Back up by H input, stop mode
69	RDS-SCK	I	Clock input for RDS
70	RDS DA	I	RDS data input
71	REMOCON	I	Remocom input
72	DETACH	I	Detach signal input H : Power save
73	BUS-INT	I	Cut-in input for J-BUS signal
74	REGCPU	-	Regulator for CPU power supply, Connect the GND with 0.1 μ F.
75	GND	-	Ground
76	X2	-	Connecting the crystal oscillator for system clock
77	X1	I	Connecting the crystal oscillator for system clock
78	REGOSC	-	Regulator for oscillator circuit. Connect the GND with 0.1 μ F.
79	VDD	-	Vdd
80	NC	-	Pull up

■ CXA2510AQ (IC901) : Head AMP / Dolby

1. Pin Layout & Block Diagram

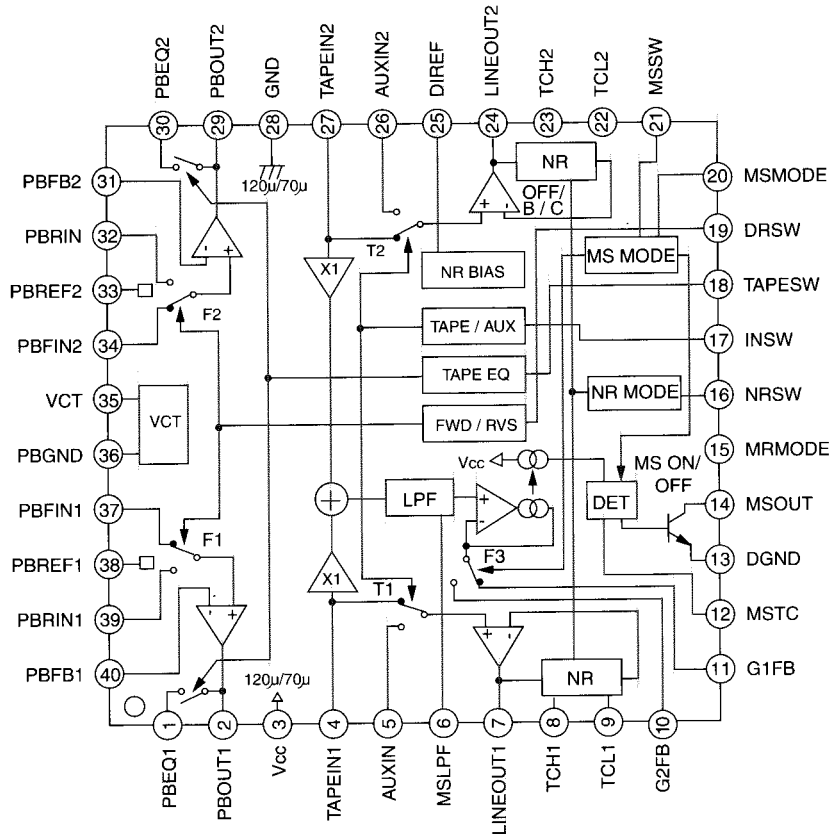

2. Pin Functions

Pin No.	Symbol	I/O	Functions
1	PBEQ1	O	Resistance for selecting the equalizer amplifier time constant.
2	PBOUT1	O	Playback equalizer amplifier out put.
3	Vcc	-	Power supply
4	TAPEIN1	I	TAPE input.
5	AUXIN1	I	External input.
6	MSLPF	-	Cut-off frequency adjustment of the music sensor LPF.
7	LINEOUT1	O	Line out.
8	TCH1	-	Time constant for the HLS.
9	NC	-	Non connection.
10	G2FB	-	Music signal interval detection level setting.
11	G1FB	-	
12	MSTC	-	Time constant for detecting the music signal interval.
13	DGND	-	Logic ground (Connect to GND)
14	MSUOT	O	Music sensor output.
15	NC	I	Non connection.

Pin No.	Symbol	I/O	Functions
16	NRSW	I	Dolby NR control L:NR OFF H:NR ON
17	INSW	I	Line amplifier input select control L:TAPE IN H:AUX IN
18	METAL	I	Playback equalizer amplifier control L:120us H:70us
19	DRSW	I	Head select control L:FORWARD H:REVERSE
20	FF/REW	I	Music sensor mode control Low(open):G1 High:G2
21	MSSW	I	Music sensor control Low(open):MS on High:MS OFF
22	NC	-	Non connection
23	TCH2	-	Time constant for the HLS
24	LINEOUT2	O	Line output
25	DIREF	-	Resistance for setting the reference current (Connects 20(18)K Ω between DIREF pin and GND for the standard setting.)
26	NC	-	Non connection.
27	TAPEIN2	I	TAPE input.
28	GND	-	To ground.
29	PBOUT2	O	Playback equalizer amplifier output.
30	PBEQ2	O	Resistance for selecting the playback equalizer amplifier time constant
31	PBFB2	I	Playback equalizer amplifier feedback.
32	NC	-	Non connection.
33	PBREF2	O	Playback equalizer amplifier reference (Vcc/2 output)
34	PBFIN2	I	Playback equalizer amplifier input (FORWARD head connected)
35	VCT	O	Center (Vcc/2 output)
36	PBGND	-	Playback equalizer amplifier ground (Connect to ground)
37	PBFIN1	I	Playback equalizer amplifier input (FORWARD head connected)
38	PBREF1	O	Playback equalizer amplifier reference (Vcc/2 output)
39	NC	-	Non connection.
40	PBFB1	I	Playback equalizer amplifier feedback.

■ BA3880FS-X(IC921) : BBE

1. Pin layout & Block Diagram

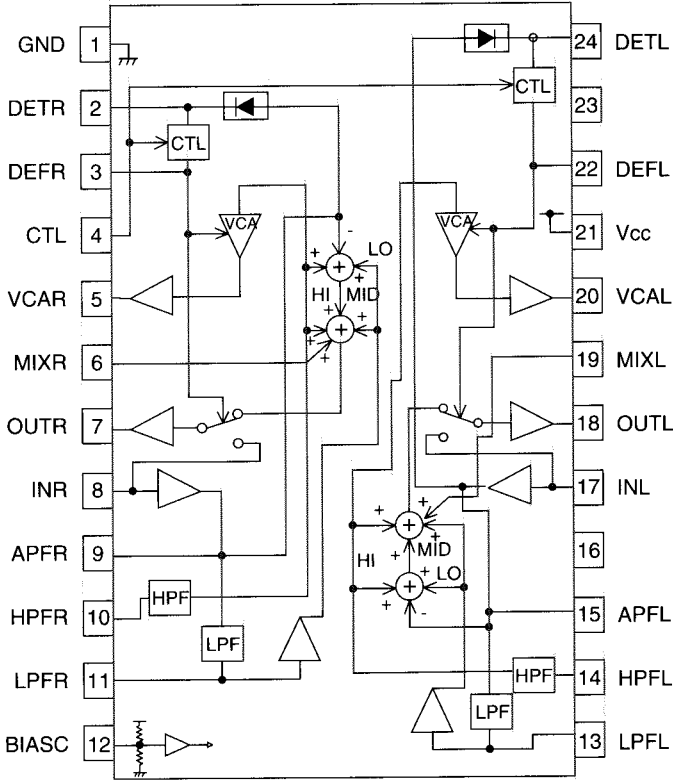

2. Pin Functions

Pin No.	Symbole	Function	Pin No.	Symbole	Function
1	GND	Grounding terminal	13	LPFL	LPF output terminal
2	DETR	Peak level detector output for treble VCA control	14	HPFL	HPF output terminal
3	DEFR	Control signal time constant terminal	15	APFL	Input inversion amplifier output terminal
4	CTL	Control signal input terminal	16		Non connector
5	VCAR	Treble CA output terminal	17	INL	Signal input terminal
6	MIXR	Output MIX amplifier summing terminal	18	OUTL	Signal output terminal
7	OUTR	Signal output terminal	19	MIXL	Output MIX amplifier summing terminal
8	INR	Signal input terminal	20	VCAL	Treble CA output terminal
9	APFR	Input inversion amplifier output terminal	21	VCC	Power supply terminal
10	HPFR	HPF output terminal	22	DEFL	Control signal time constant terminal
11	LPFR	LPF output terminal	23		Non connector
12	BIASC	Reference voltage output terminal (1/2 Vcc)	24	DETL	Peak level detector output for treble VCA control

■ BA4901A-V3 (IC961) : Regulator

1. Pin layout

VCC-C	1
VCC-B	2
ACC5V	3
ACC.IN	4
VDD5V	5
9V	6
CDBV	7
CTRL	8
MEMORY.IN	9
10V	10
AJ	11
GND	12

2. Pin Function

Pin No.	Symbol	Descriptions
1	VCC-C	To be connected with the collector of PNP.
2	VCC-B	To be connected with the base of PNP.
3	ACC5V	A voltage supply for ACC block.
4	ACC.IN	Control of the COMP output by inputting voltage.
5	VDD5V	Output voltage level is 5.7V, and max output current is 100mA. This voltage supply is for microcomputer. Whenever backup voltage supply is connected, the output keeps on running.
6	9V	This output voltage is 9.0V, and max output current is 500mA. This voltage supply for AUDIO.
7	CDBV	This output voltage is 8.0V, and max output current is 1A This voltage supply for CD.
8	CTRL	Output selector of CD, AUDIO, ILM and Vcc-B.
9	MEMORY.IN	To be connected with the BACKUP of car
10	10V	This output voltage is 10V, and max output current is 500mA. Output voltage is adjustable.
11	AJ	Putting a resistance between ILM and AJ or between AJ and GND males ILM output voltage adjustable.
12	GND	Connect to GND

■ LC75385NE-R (IC911) : Electronic Volume

1. Terminal Layout

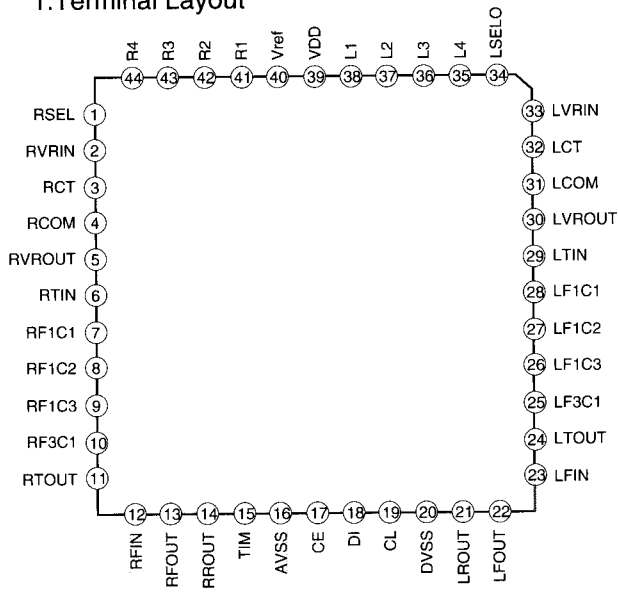

2. Block Diagram

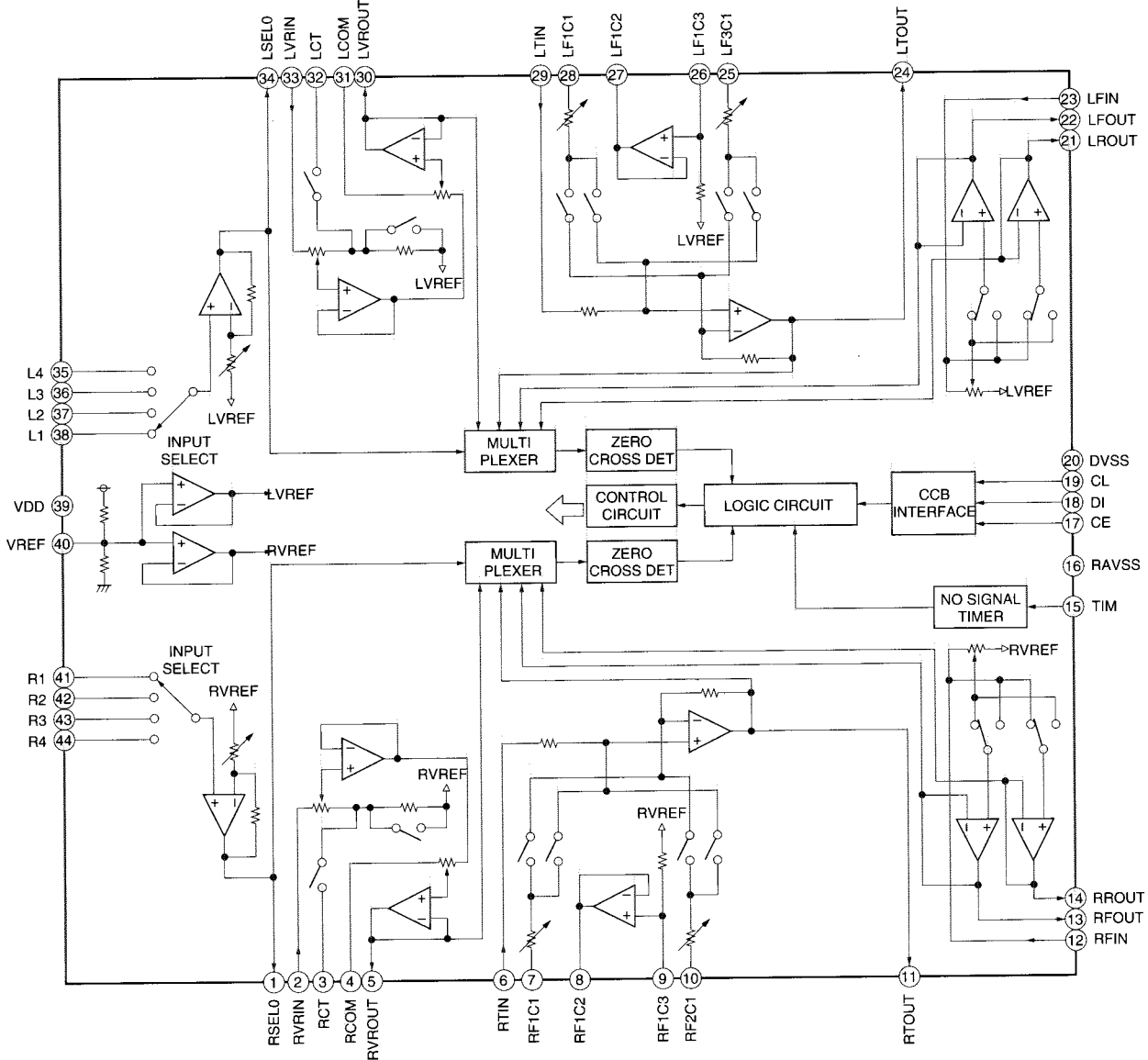

■ LC75873NW (IC601) : LCD driver

1. Pin Layout

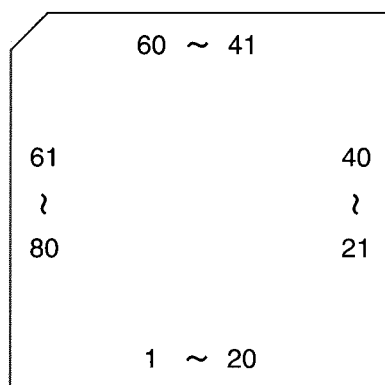

2. Pin function

Pin NO.	Symbol	I/O	Function
1 to 66	SEG3 to SEG69	O	Segment output terminal
67 to 69	COM1 ~ COM3	O	Common driver output terminal
70	VDD	—	Power supply connection
71	VDD1	I	Used for applying the LCD driver 2/3 bias voltage externally
72	VDD2	I	Used for applying the LCD driver 1/3 bias voltage externally
73	VSS	—	Power supply connection Connect to ground
74	OSC	I/O	Oscillator connection
75	INH	I	Display off control input
76	CE2	I	Serial data transfer inputs
77	CL	I	Serial data transfer inputs
78	DI	I	Serial data transfer inputs
79	DIMMER	O	Segment output terminal
80	NC	—	Non connection

■ NJM2100M-WE (IC781) : Dual ope. amp

1. Pin layout

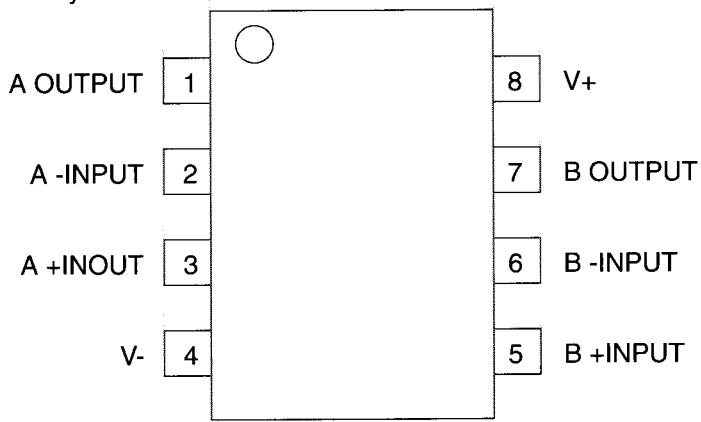

2. Block diagram

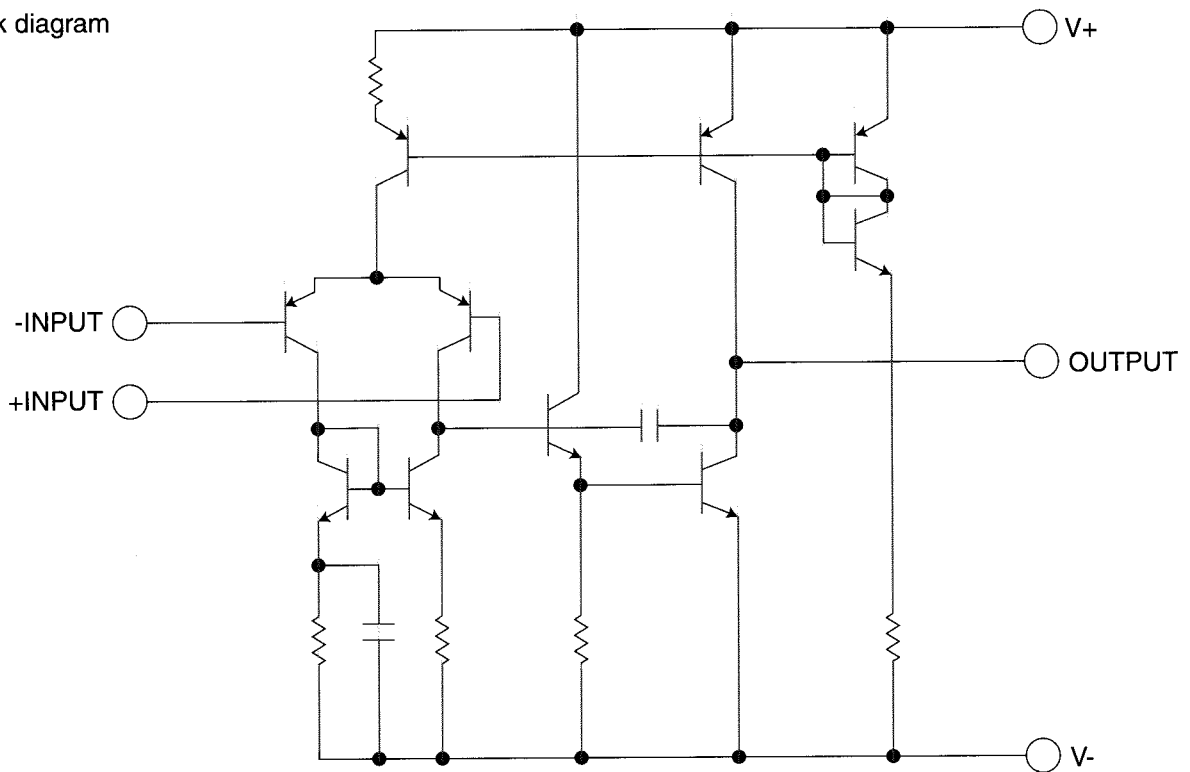

■ SAA6579T-X (IC761) : RDS Demodulator

1. Pin layout

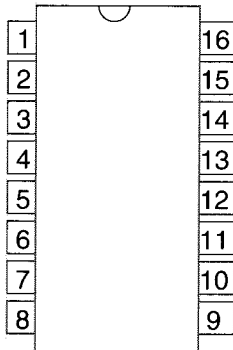

2. Pin function

Pin No.	Symbol	Function
1	QUAL	Quality indication output
2	RDDA	RDS data output
3	Vref	Reference voltage output (0.5VDDA)
4	MUX	Multiplex signal input
5	VDDA	+5V supply voltage for analog part
6	VSSA	Ground for analog part (0V)
7	CIN	Subcarrier input to comparator
8	SCOUT	Subcarrier output of reconstruction filter
9	MODE	Oscillator mode / test control input
10	TEST	Test enable input
11	VSSD	Ground for digital part (0V)
12	VDDD	+5V supply voltage for digital part
13	OSCI	Oscillator input
14	OSCO	Oscillator output
15	T57	57kHz clock signal output
16	RDCL	RDS clock output

3. Block diagram

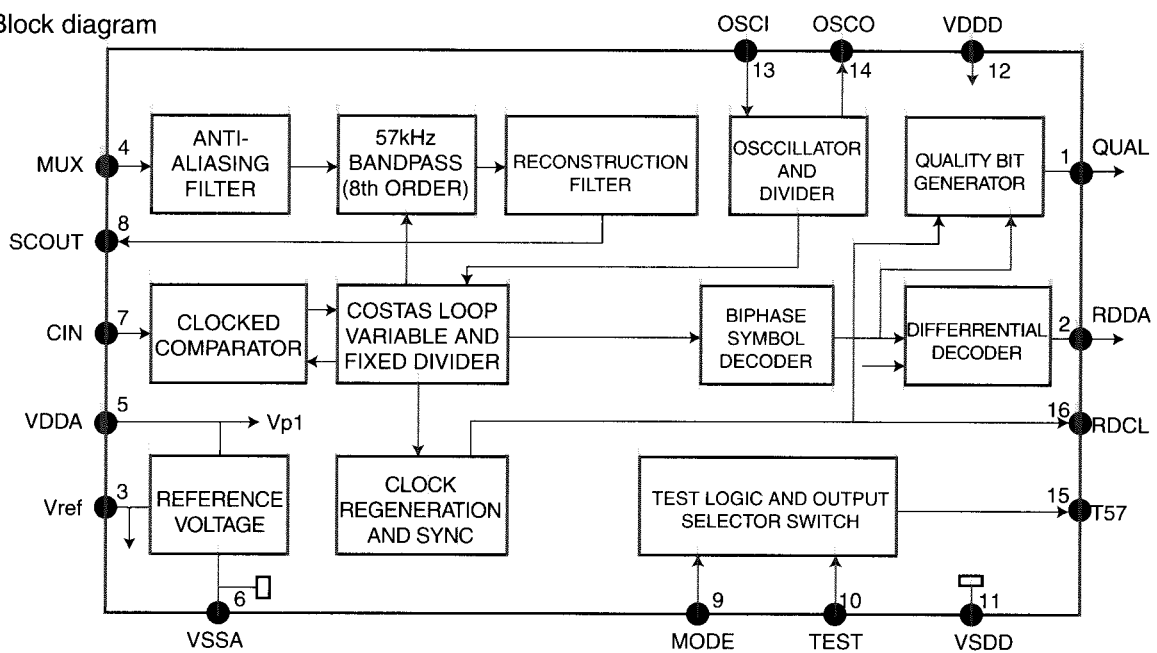

■ TDA8568Q/N3 (IC941) : POWER AMPLIFIER

1. Block Diagrams

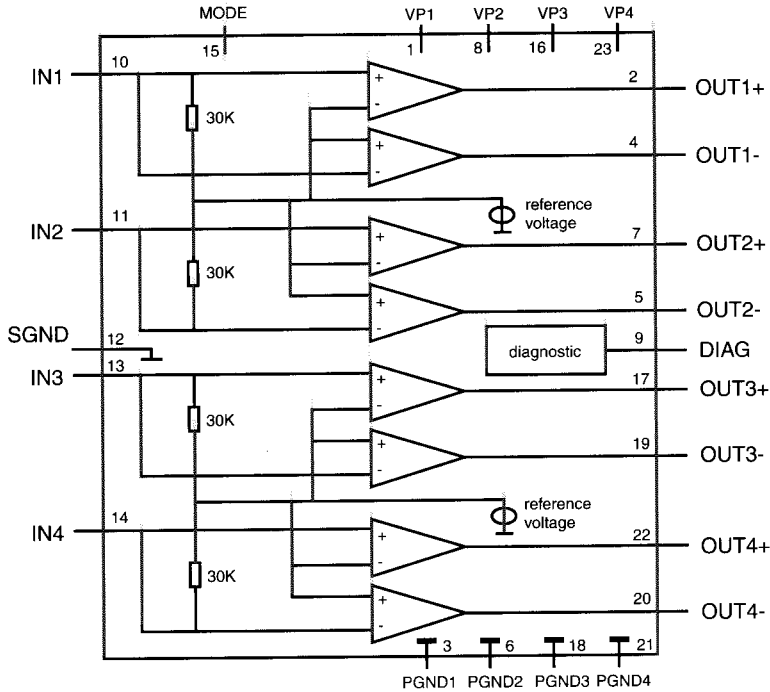

2. Pin Function

Pin No.	Symbol	I/O	Descriptions
1	VCC	-	Supply voltage 1
2	OUTFR+	O	Output 1+
3	GND1	-	Power ground 1
4	OUT1FR-	O	Output 1-
5	OUT2RR-	O	Output 2-
6	GND2	-	Power ground 2
7	OUT2RR+	O	Output 2+
8	VCC	-	Supply voltage 2
9	DIAG OUT	O	Diagnostic output
10	IN1FR	I	Input 1
11	IN2RR	I	Input 2
12	GND	-	Signal ground
13	IN3RL	I	Input 3
14	IN4FL	I	Input 4
15	MODE	O	mode select switch (Stand-by / mute / operating)
16	VCC	-	Supply voltage 3
17	OUT3RL+	O	Output 3+
18	GND3	-	Power ground 3
19	OUT3RL-	O	Output 3-
20	OUT4FL-	O	Output 4-
21	GND4	-	Power ground 4
22	OUT4FL+	O	Output 4+
23	VCC	-	Supply voltage 4

■ LB1641 (IC501) : Moter driver

1. Block Diagram

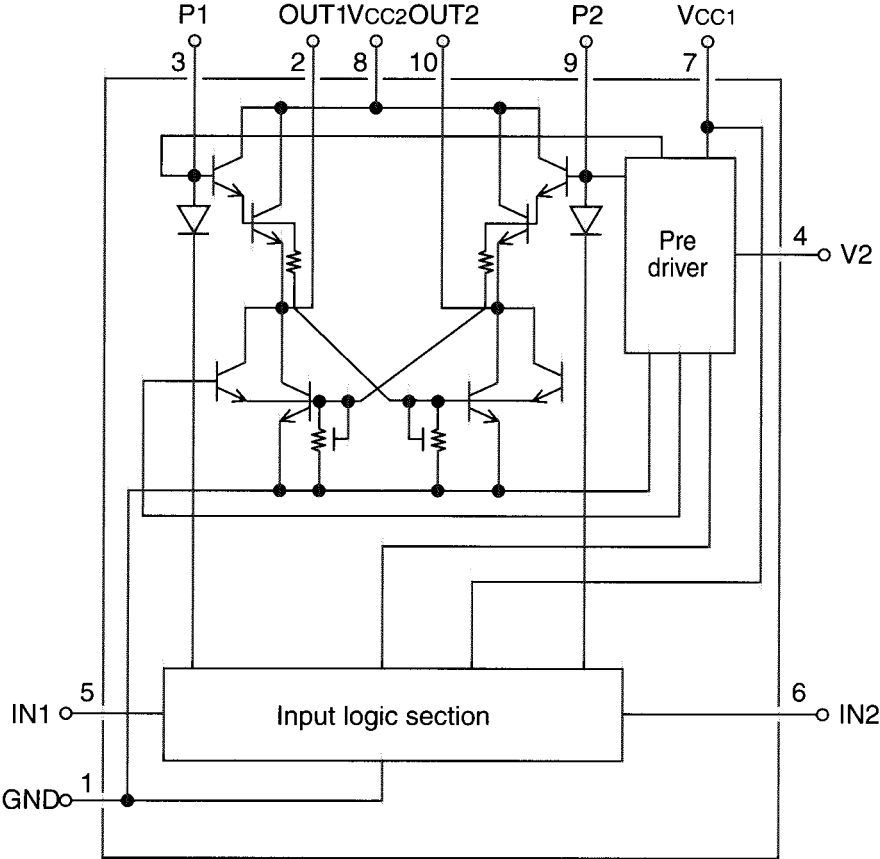

■ RPM6938-SV4 (IC602) : Remote control receiver

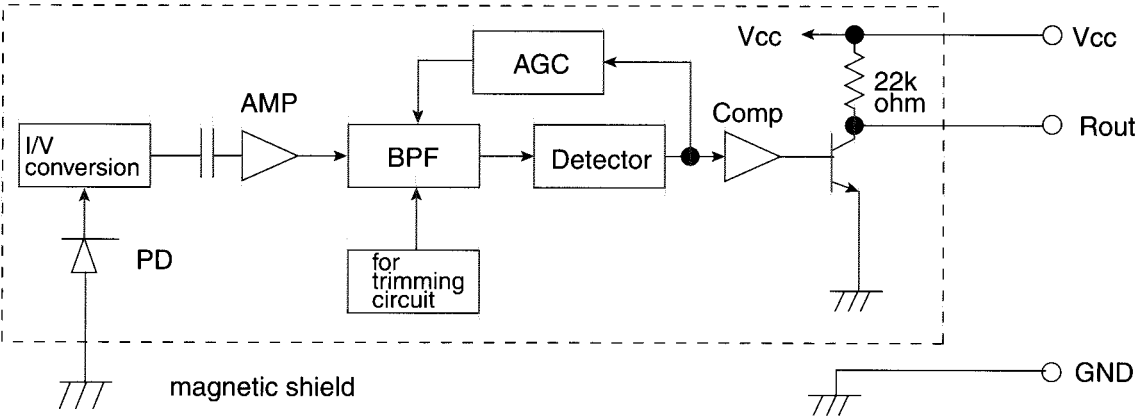

■ HD74HC126FP-X (IC631) : Buffer

1. Pin layout

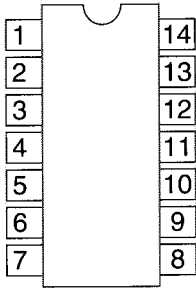

2. Function

Inputs		Outputs
C	A	Y
L	X	Z
H	L	H
H	H	L

3. Block diagram

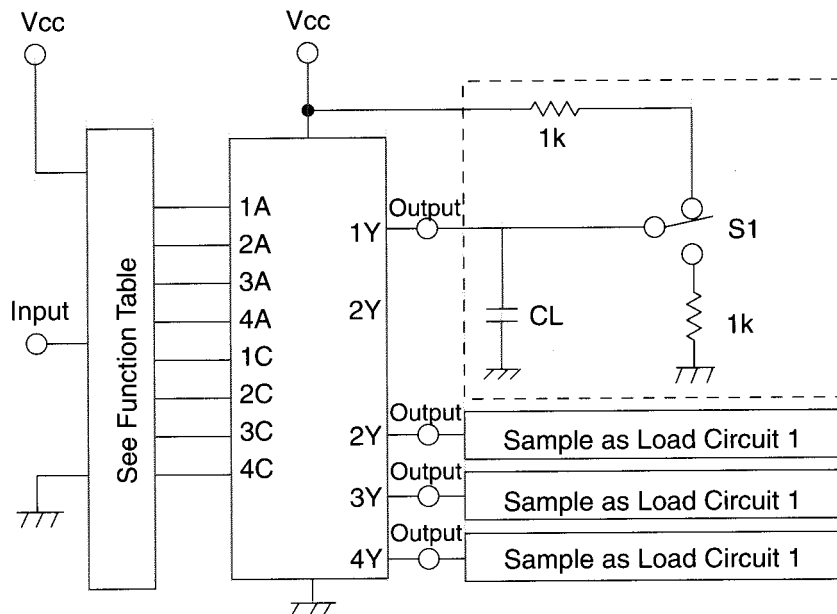

■ BU4066BCF-X (IC173) : Switch

1. Terminal Layout

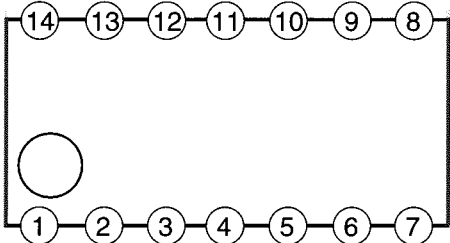

2. Block Diagram

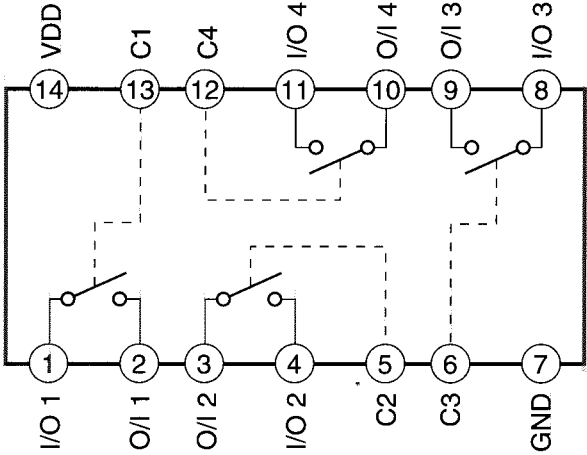

Block diagram

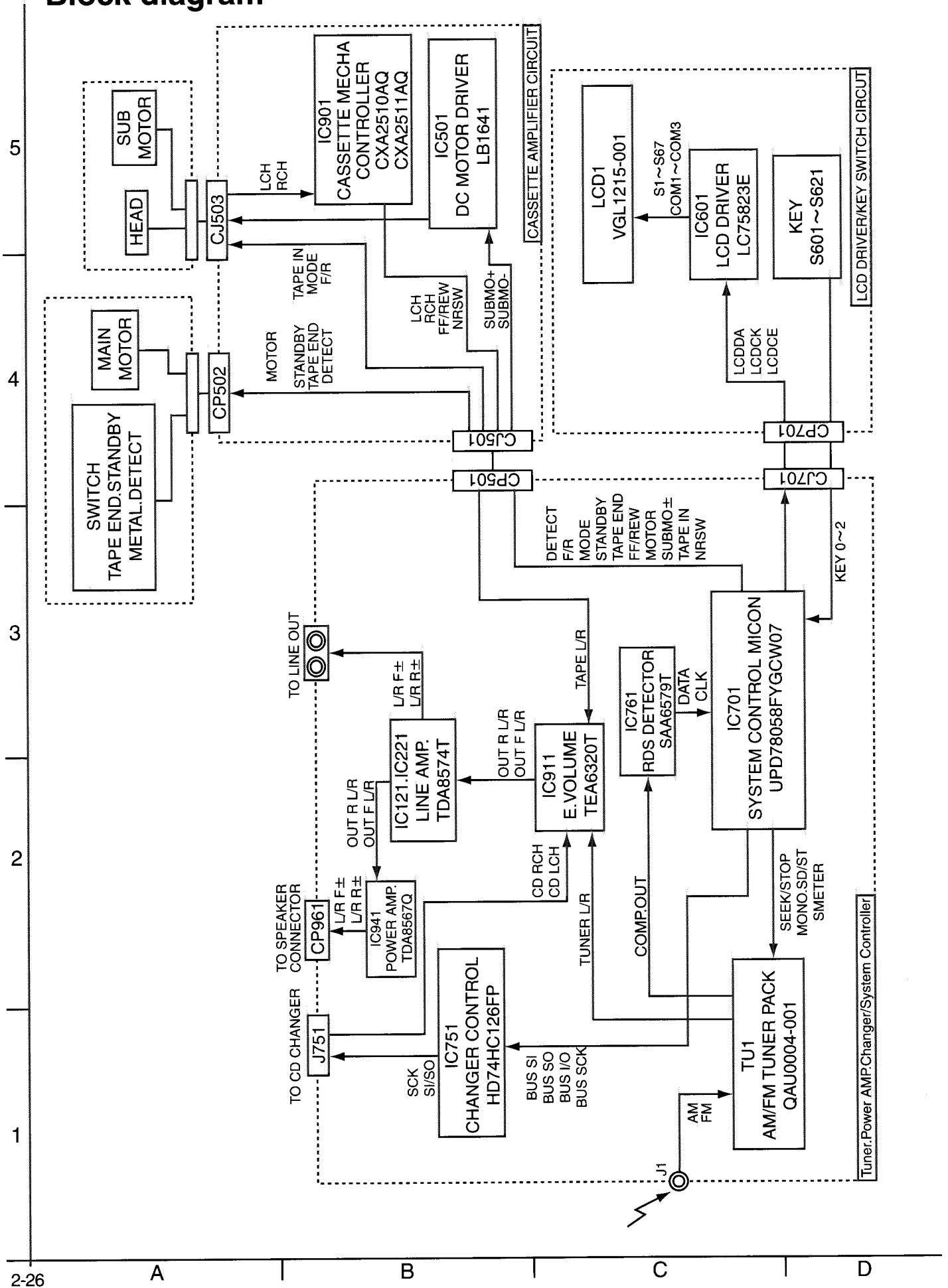

Standard schematic diagrams

■ Head amplifier circuit

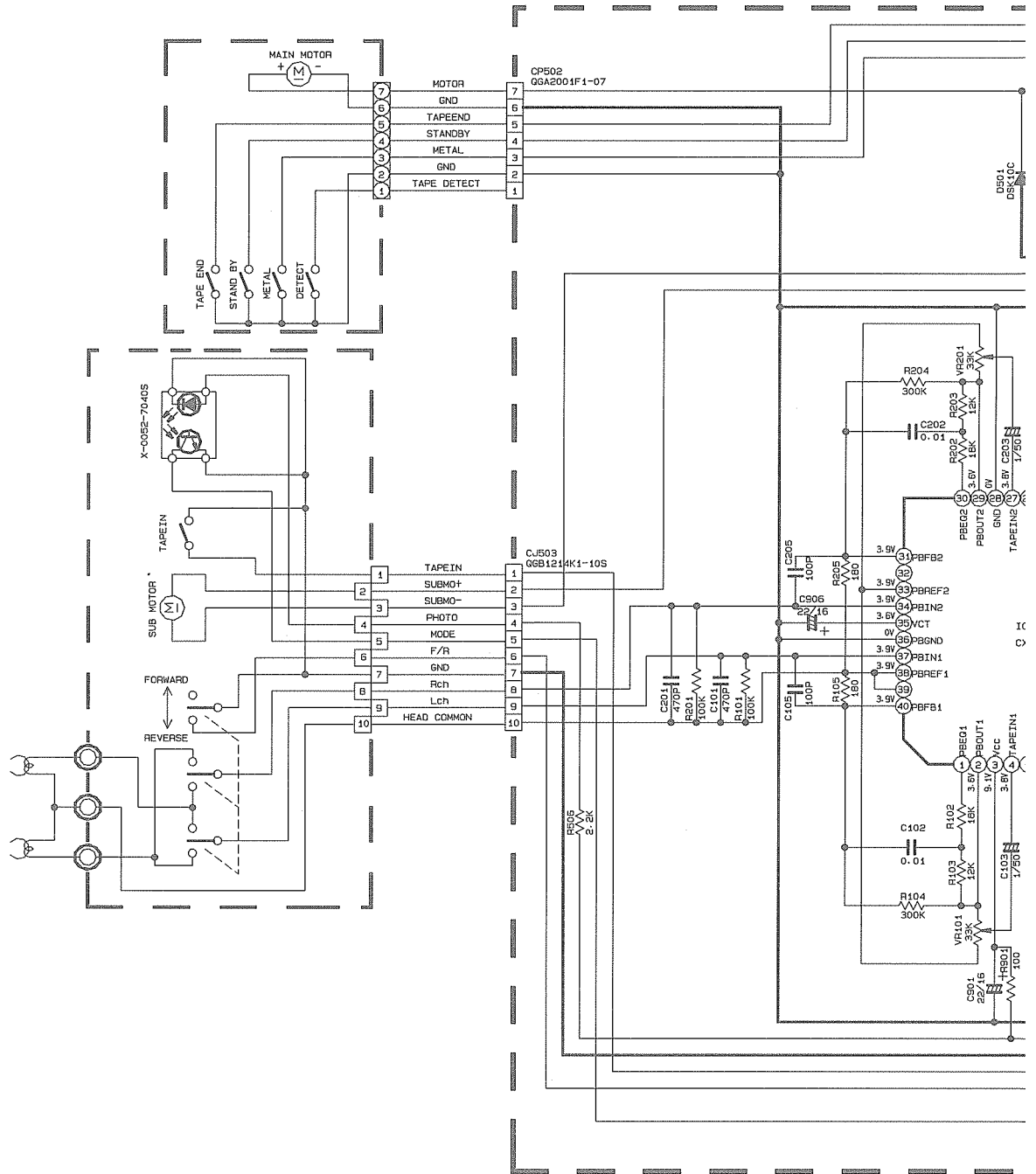

Note : FSDH3072005MW

5

4

3

2

1

A

B

C

D

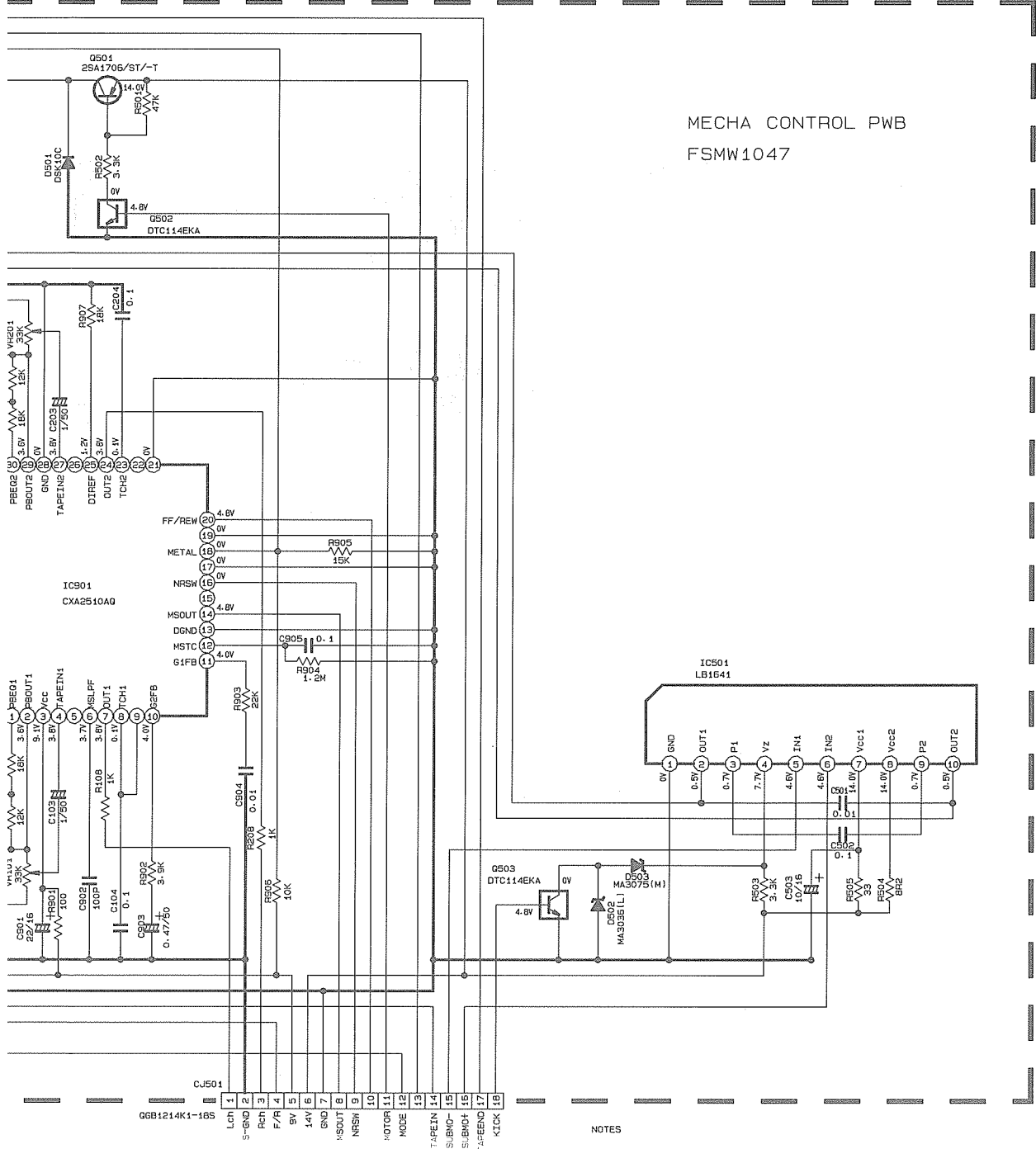

MECHA CONTROL PWB
FSMW1047

NOTES

1. VOLTAGES ARE DC-MEASURED WITH A DIGITAL VOLT METER WITHOUT INPUT SIGNAL. CONDITION-----TAPE MODE.
2. UNLESS OTHERWISE SPECIFIED.
ALL RESISTORS ARE 1/4W ±5% OR 1/10W ±5% METAL GLAZE RESISTOR.
ALL CAPACITORS ARE 50V CERAMIC CAPACITOR.
ALL RESISTANCE VALUES ARE IN OHM(Ω).
ALL CAPACITANCE VALUES ARE IN pF(P=pF).
ALL E-CAPACITORS ARE SHOWN IN THE FORM OF CAPACITANCE(μF)/RATED VOLTAGE(V)

TF-----TF CAPACITOR

■ LCD & operation switch circuit

5

4

3

2

1

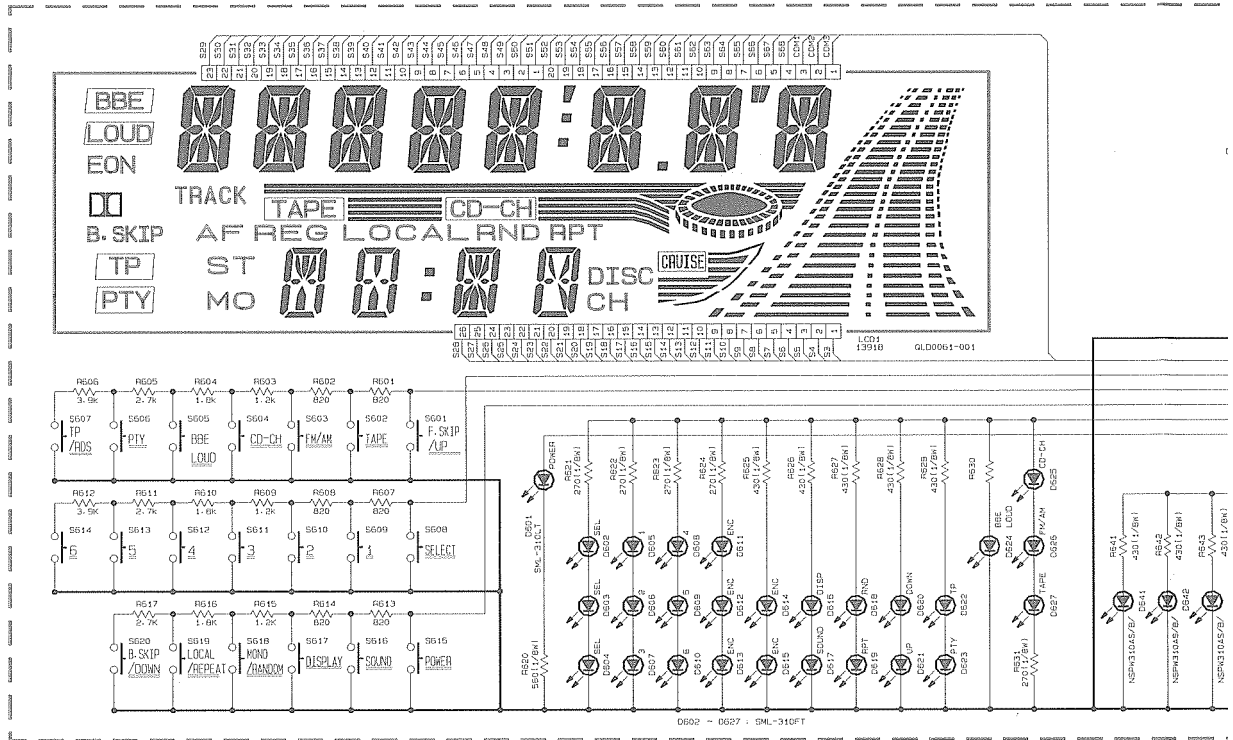

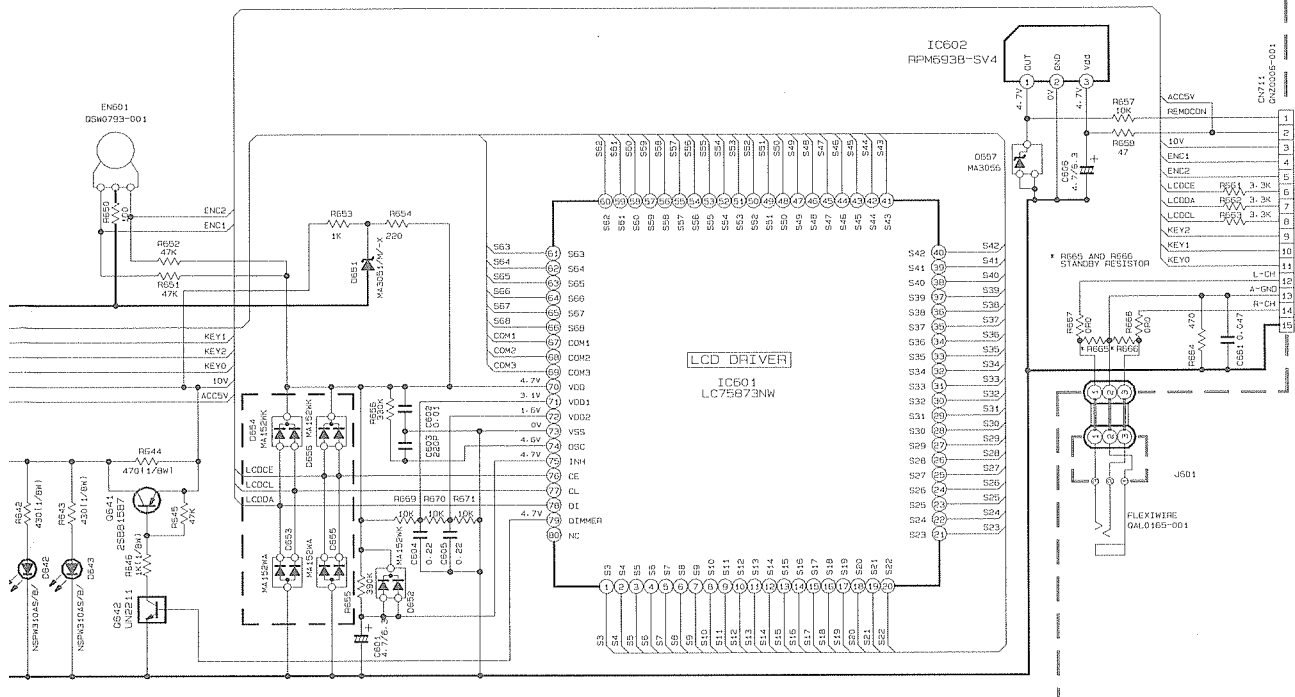

Receiver & power amplifier circuit

- CONDITION--FM
 NOTES 1. VOLTAGES ARE DC-MEASURED WITH A DIGITAL CONDITION--FM MODE. □ AM MODE
 2. UNLESS OTHERWISE SPECIFIED:
 ALL RESISTORS ARE 1/10W OR 1/4W 15% ME.
 ALL CAPACITORS ARE 50V OR 25V CERAMIC I
 ALL RESISTANCE VALUES ARE IN Ohm.
 ALL CAPACITANCE VALUES ARE IN uF Ip-PF I
 ALL C CAPACITORS ARE SHOWN IN THE FORM
 TF --- T. F. CAPACITOR
 N --- N. F. CAPACITOR

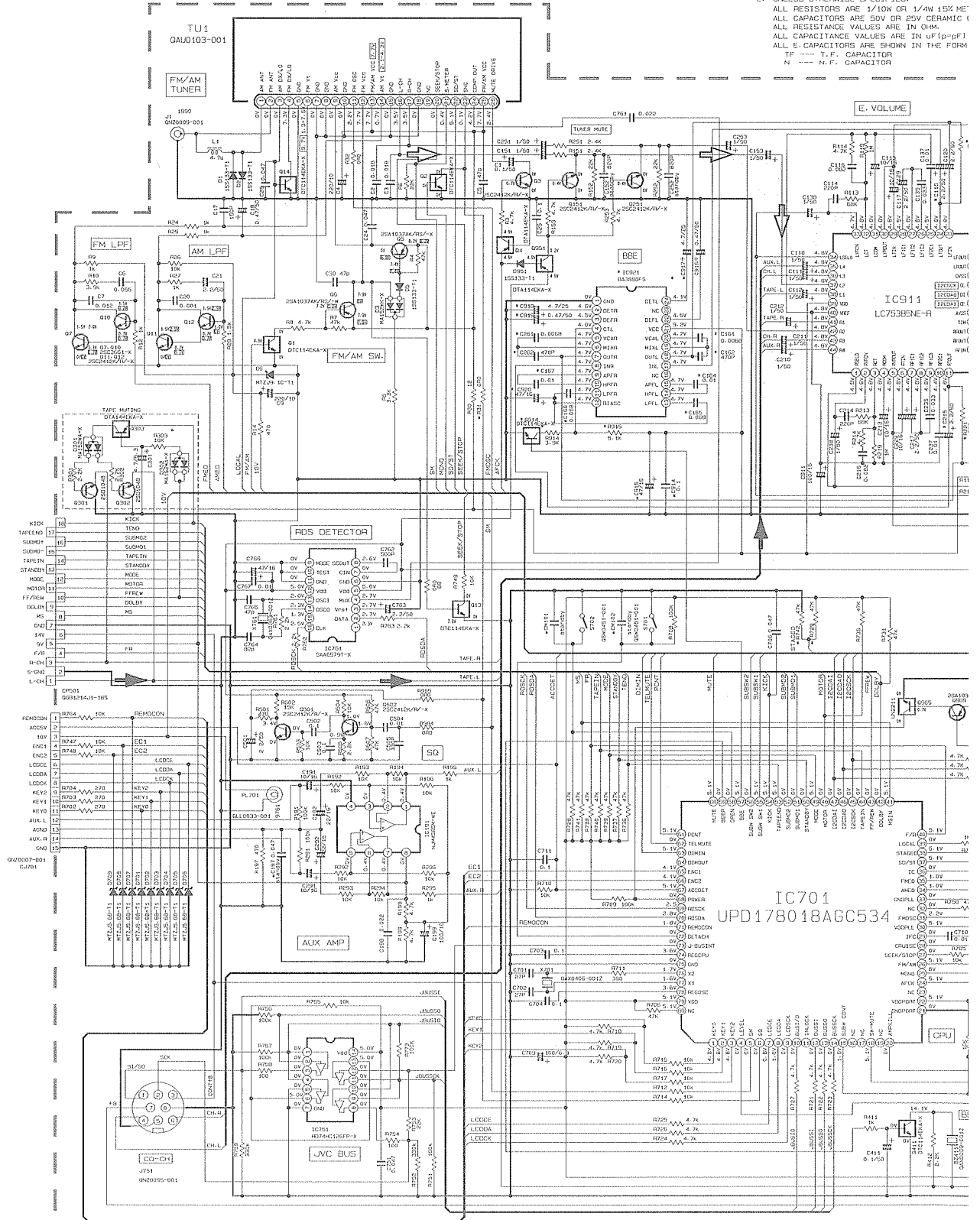

TH A DIGITAL VOLT METER WITHOUT INPUT SIGNAL
M MODE

1/4W 1% METAL GLAZE RESISTOR.
15V CERAMIC CAPACITOR.
N OSM.
IN uF 10⁻⁹PF 1
IN THE FORM OF CAPACITANCE(uF)/RATED VOLTAGE(V)

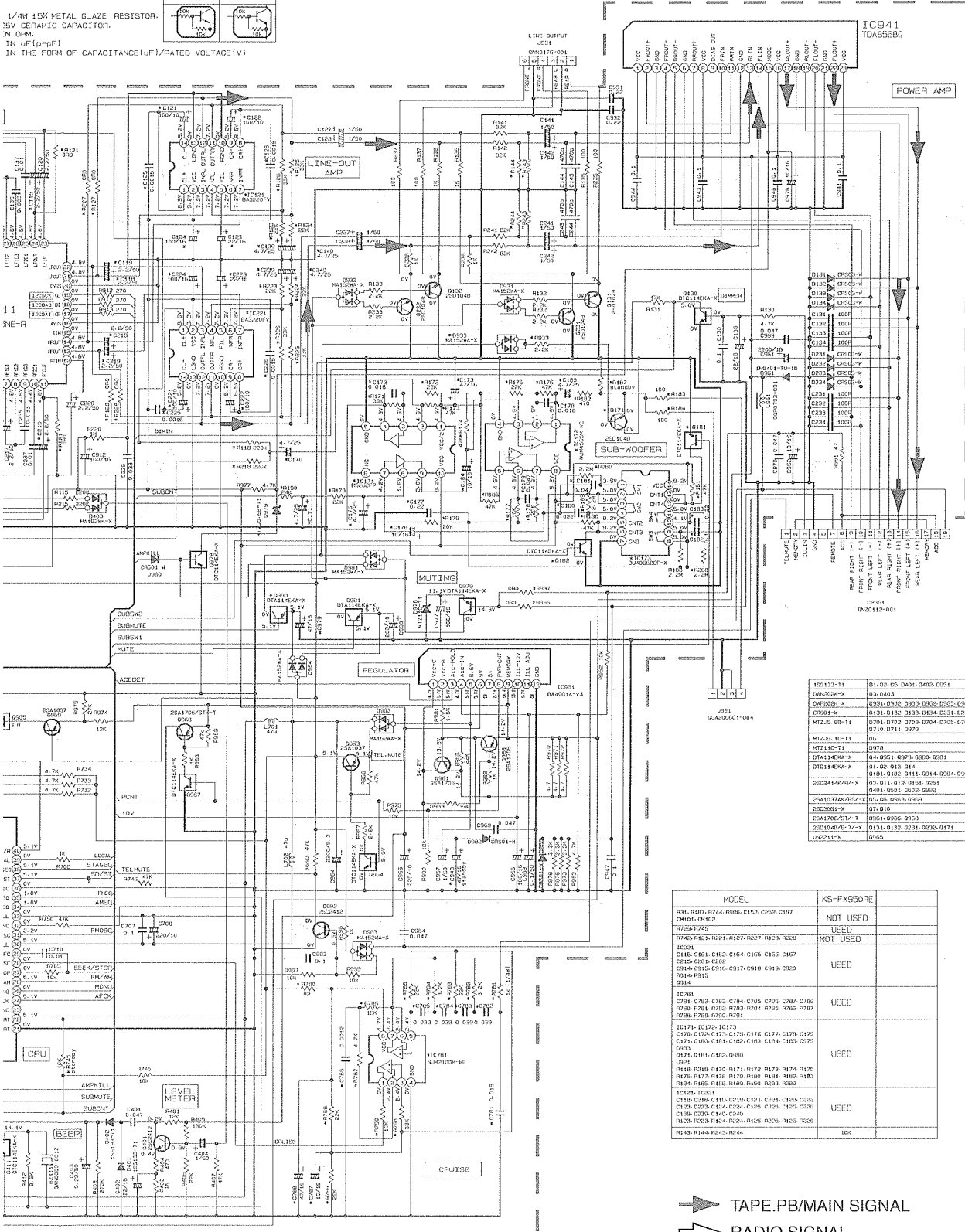
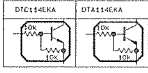

101332-11	D1-05-05-D001-D400-0501
DMS200K-X	03-0403
DMP000K-X	0301-0320-0333-0362-0363-0381-0383-0384
CR201-W	0131-0132-0133-0134-0311-0250-0253-0234-0265
MT2-5-08-11	0704-0705-0706-0708-0709-0710-0711-0708-0709
	0710-0711-0729
MT209-1C-T1	06
MT215C-T1	0928
DT1148KA-X	04-0261-0271-0280-0281
DT1148KA-X	01-01-013-014
	0100-0205-0411-0414-0504-0507-0508
DS2414KAV-X	01-01-013-014-0201
	0401-0501-0502-0503
DS1037AK/RS-X	05-05-0503-0509
DS2414K-X	10-010
DS14702/ST-V-X	0301-0306-0306
DS1484VE-7-X	0131-0132-0231-0230-0171
LM9211-X	0205

MODEL	KS-FX950RE
R01-R107-R144-R166-C152-C163-C197	NOT USED
C164-C165	USED
R122-R145	NOT USED
R142-R121-R021-R127-R027-R130-R120	NOT USED
C101-C161-C162-C164-C165-C166-C167	USED
C18-0216-C202	USED
C184-C215-C195-C197-C198-C199-C196-C193	USED
R114-R115	USED
C171-C172-C173-C175-C185-C186-C177-C178-C179	USED
C171-C180-C181-C182-C183-C184-C185-C191	USED
0201	USED
R116-R118-R119-R171-R172-R173-R174-R175	USED
R176-R177-R178-R179-R180-R181-R182-R183	USED
R184-R185-R186-R187-R188-R189-R190-R191	USED
C123-C124	USED
C118-C119-C110-C109-C101-C102-C103-C102	USED
C109-C103-C104-C104-C105-C105-C106-C106	USED
C138-C139-C140-C140	USED
R120-R123-R124-R124-R125-R126-R126-R126	USED
R143-R144-R143-R144	NOT

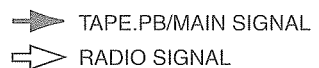

MAIN PWB : FSMW1068

Printed circuit boards

■ Main board

(Parts side)

5

4

3

2

1

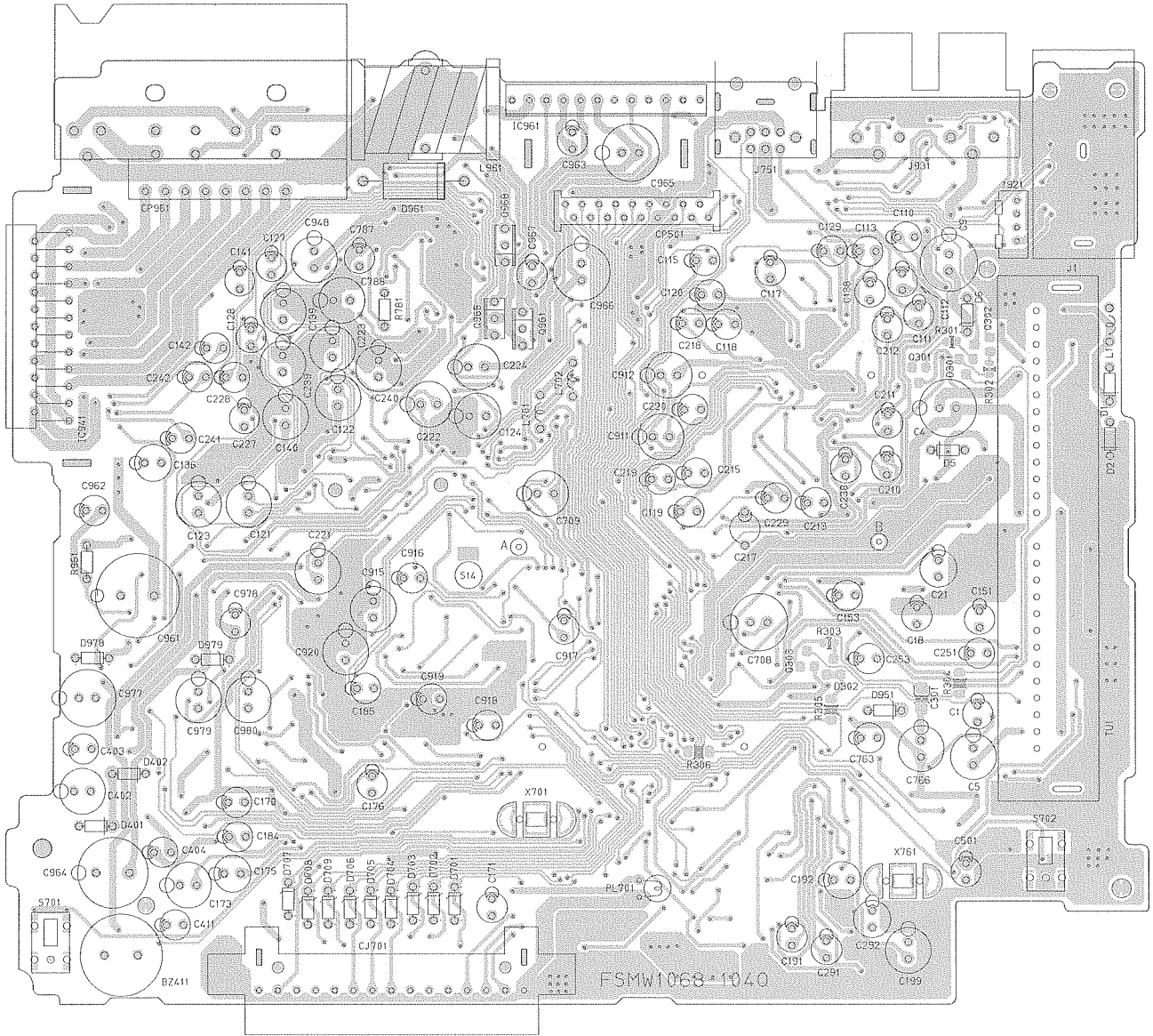

FSMW1068-1040

■ Main board

(Solder side)

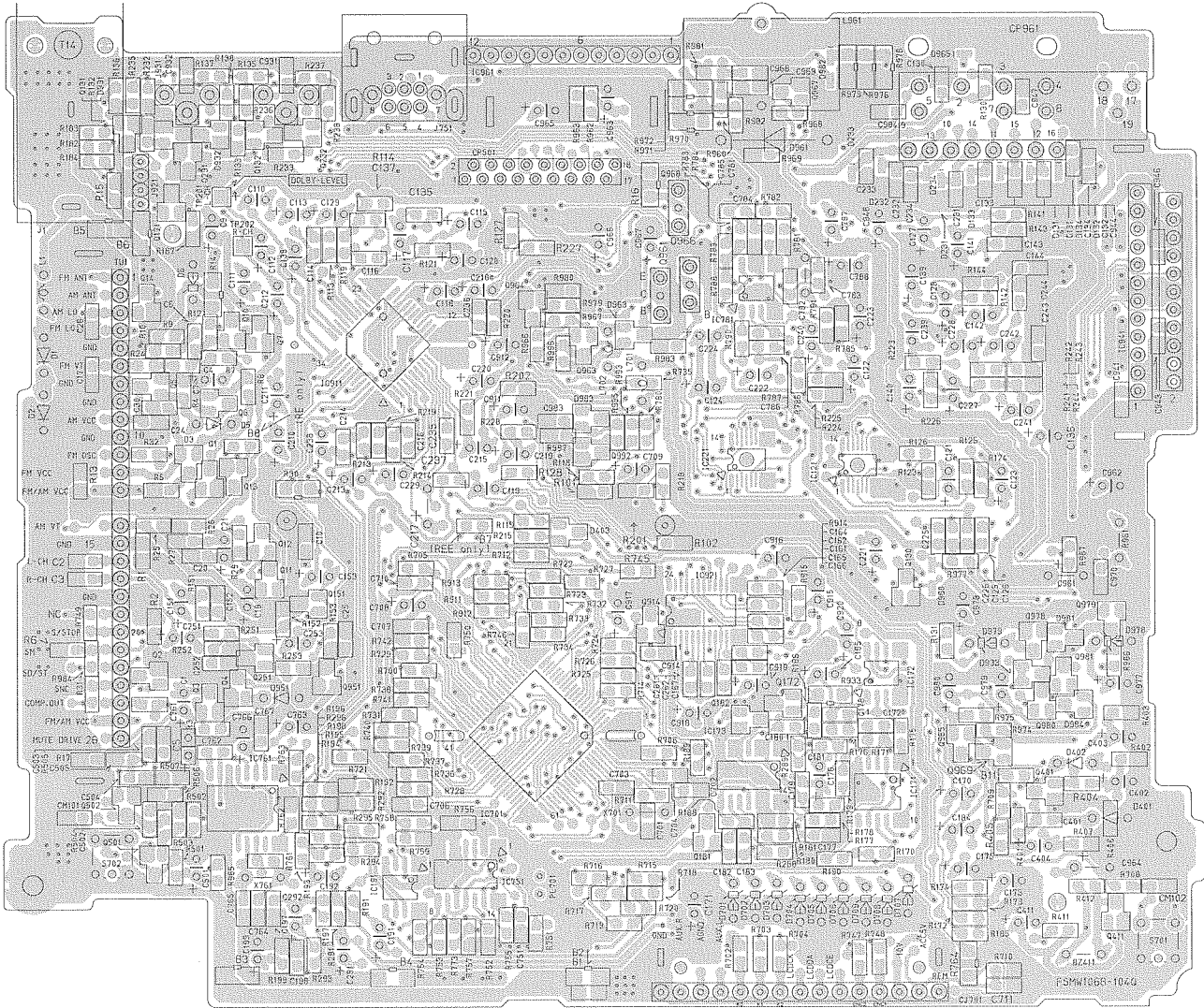

5

■ Mecha control board

(Solder side)

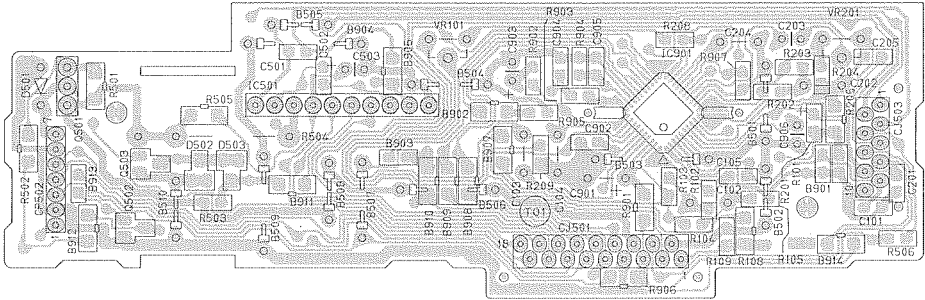

4

(Parts side)

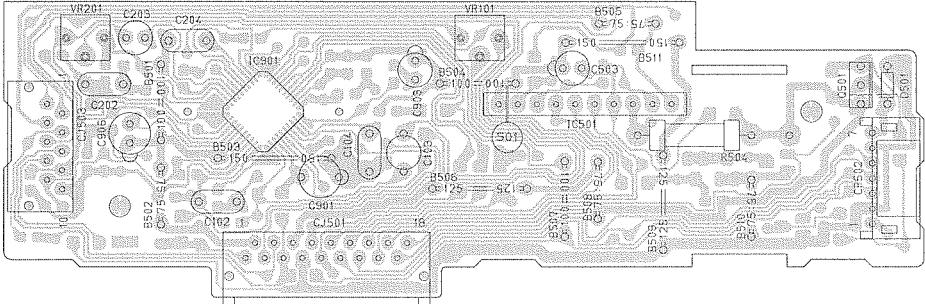

3

2

1

A

B

C

5

■ Switch board

(Solder side)

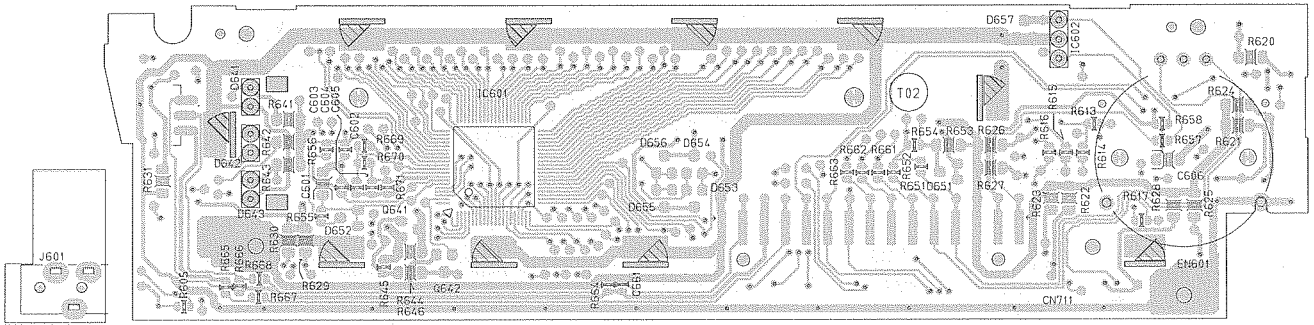

4

(Parts side)

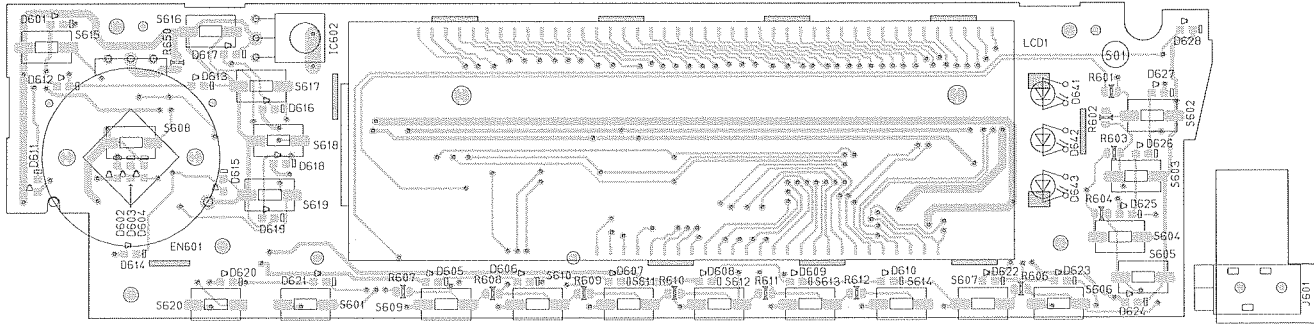

3

2

1

PARTS LIST

[KS-FX950R]

* All printed circuit boards and its assemblies are not available as service parts.

Areas suffix

E ----- Continental Europe

- Contents -

Exploded view of general assembly and parts list	3-3
Cassette mechanism assembly and parts list	3-5
Electrical parts list	3-8
Packing materials and accessories parts list	3-14

KS-FX950R

-MEMO-

Exploded view of general assembly and parts list

Block No. M 1 M M

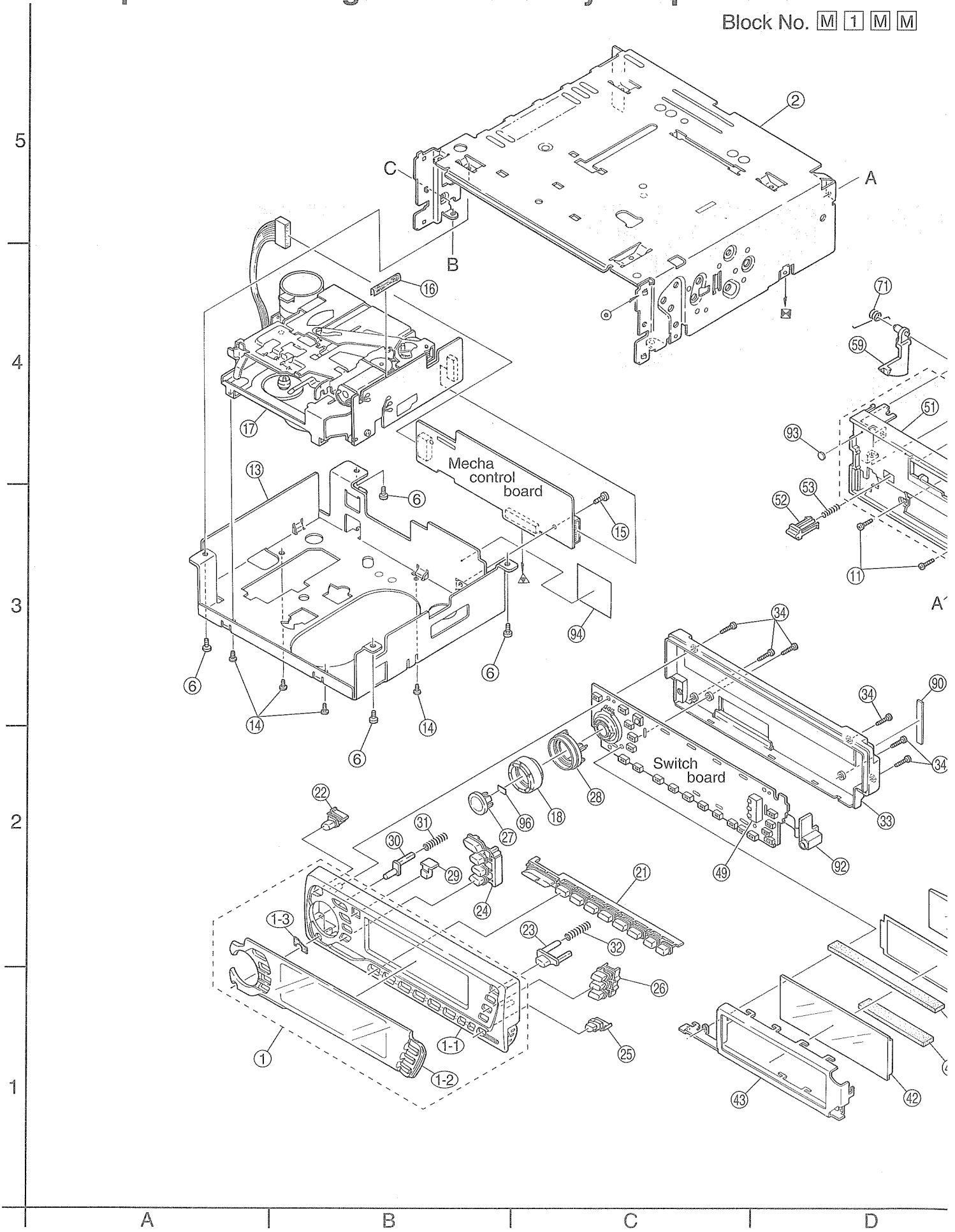

M

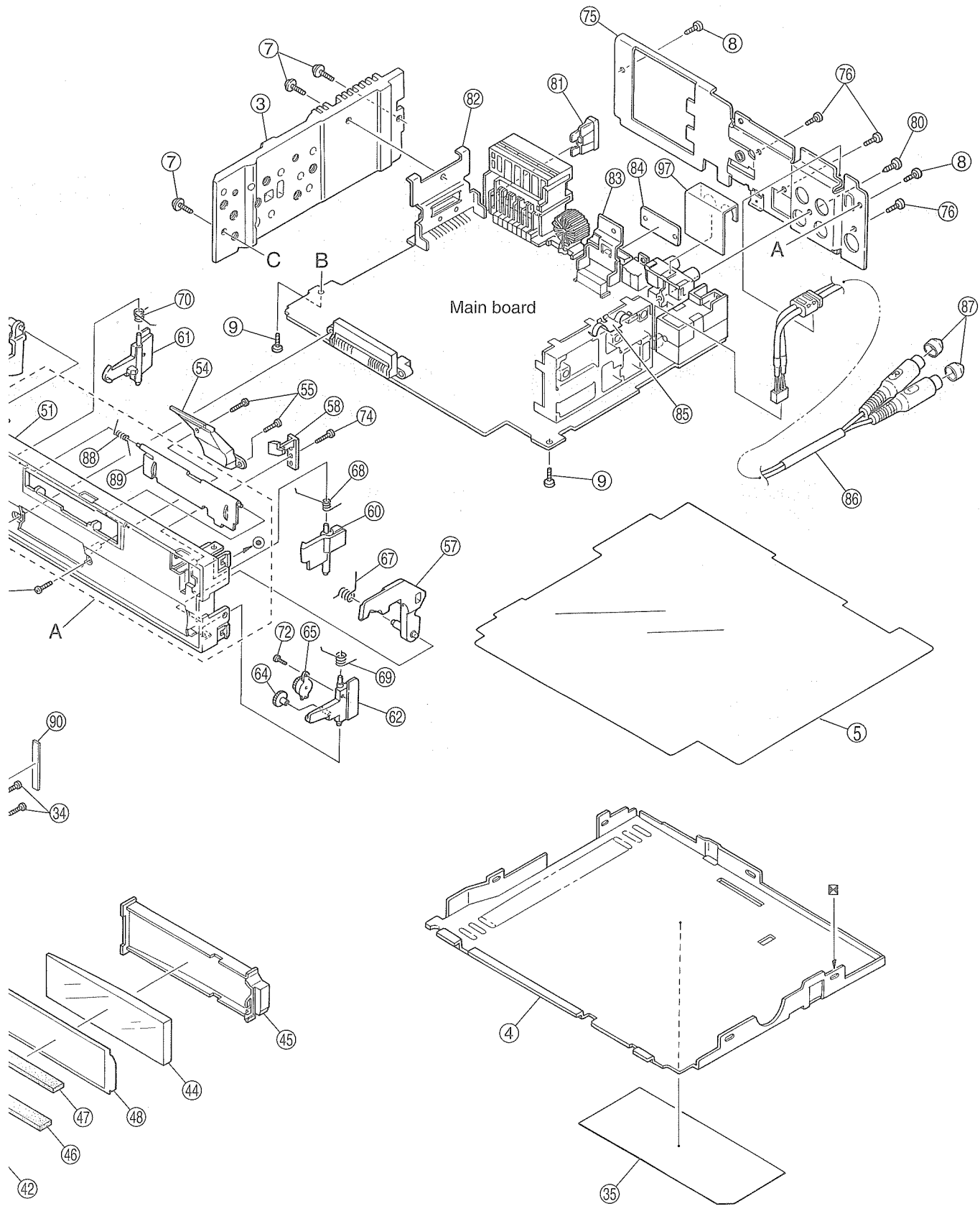



Block No. M1MM

△	Item	Parts number	Parts name	Q'ty	Description	Area
	A	ZCKSFX840R-FB	FRONT CHASSIS	1	NO.51 88 89	
	1	ZCKSFX950R-NPA	F.PANEL ASS'Y	1		
	1-1	FSJC1044-001	FRONT PANEL	1		
	1-2	FSJD3018-00H	FINDER ASSY	1		
	1-3	FSYH4069-001	SHEET	1		
	2	FSJC1029-015	TOP CHASSIS	1		
	3	FSMH3001-202	SIDE PANEL	1		
	4	FSKM3011-002	BOTTOM COVER	1		
	5	FSMA3005-001	INSULATOR	1		
	6	QYSDST2604Z	SCREW	4	CHASSIS+MECHA.B	
	7	FSKZ4005-001	SCREW	3		
	8	QYSDST2606Z	SCREW	2	CHASSIS+REAR BK	
	9	QYSDST2606Z	SCREW	2	CHASSIS+MAIN PW	
	11	QYSDSF2006M	SCREW	2		
	13	FSKM2003-004	MECHA BRACKET	1		
	14	QYSDSP2604Z	SCREW	4		
	15	QYSDST2604Z	SCREW	1		
	16	VYSA1R4-056	SPACER	1		
	17	-----	CASSETTE MECHA	1	CDS-522VJ1	
	18	FSXK3003-005	VOL.KNOB	1	JOG DIAL	
	21	FSXP2035-052	PRESET BUTTON	1		
	22	FSXP3053-002	POWER BUTTON	1		
	23	FSXP3058-001	EJECT BUTTON	1		
	24	FSXP2037-035	PUSH BUTTON	1		
	25	FSXP4005-017	BBE BUTTON	1		
	26	FSXP2034-031	D.FUNC BUTTON	1		
	27	FSXP3061-001	SEL BUTTON	1		
	28	FSJK3027-001	RIM LENS	1	FOR KNOB	
	29	FSJK4009-001	REMOTE LENS	1	FOR REMOTE CON.	
	30	FSXP3059-001	DETACH BUTTON	1		
	31	VKW3001-330	COMP.SPRING	1	FOR DETACH BUTT	
	32	VKW3001-330	COMP.SPRING	1	FOR EJECT BUTTO	
	33	FSJC1045-001	REAR COVER	1		
	34	VKZ4777-001	MINI SCREW	6	FRONT+SW.PWB	
	35	FSYN3124-D005	NAME PLATE	1		
	42	QLD0061-001	LCD MODULE	1		
	43	FSYH3019-001	LCD CASE	1		
	44	FSJK3028-001	LCD LENS	1		
	45	FSKS3013-001	LENS CASE	1		
	46	QNZ0376-002	RUBBER CONNECTO	1		
	47	QNZ0377-002	RUBBER CONNECTO	1		
	48	FSYH4061-001	LIGHTNG SHEET	1		
	49	FSKS3017-002	LED HOLDER	1		
	51	-----	FRONT CHASSIS	1	A	
	52	FSXP3060-001	RELEASE LEVER	1		
	53	FSKW3002-016	COMP.SPRING	1	FOR RELEASE KNO	
	54	VJK3707-001	LIGHT LENS	1		
	55	QYSPSGU1745N	MINI SCREW	2	FOR LIGHT LENS	
	57	FSKS3014-001	OPEN LEVER	1		

■ Parts list (General assembly)

Block No. M1MM

△	Item	Parts number	Parts name	Q'ty	Description	Area
	58	FSKS3015-001	LOCK LEVER(O.L)	1		
	59	VKS3798-002	RELEASE LEVER	1		
	60	VKS3793-001	LOCK LEVER(TOP)	1		
	61	VKS3794-003	LOCK LEVER(L)	1		
	62	VKS3795-002	LOCK LEVER(R)	1		
	64	VKS5563-001	GEAR	1		
	65	VKZ4786-002	OIL DAMPER	1		
	67	FSKW4013-002	T.SPRING	1	FOR OPEN LEVER	
	68	FSKW4012-001	T.SPRING	1	FOR L.LEVER(TOP	
	69	VKW5262-001	T.SPRING	1	FOR L.LEVER(R)	
	70	VKW5263-002	T.SPRING	1	FOR L.LEVER(L)	
	71	VKW5264-005	T.SPRING	1	FOR RELEASE LEV	
	72	QYSDSF2006M	SCREW	1	DAMPER+L.LEVER(
	74	VKZ4777-001	MINI SCREW	1	LOCK LEVER(O.L.	
	75	FSKM3012-013	REAR BRACKET	1		
	76	QYSDST2606Z	SCREW	3		
	80	QYSDSF3006Z	SCREW	1		
△	81	QMFZ021-100-J1	FUSE	1		
	82	FSKL4018-00B	IC BRACKET	1		
	83	FSKL4015-002	REG BRACKET	1		
	84	FSKL4014-001	HEAT SINK	1		
	85	VMA4652-001SS	EARTH PLATE	1		
	86	QAM0154-001	SUB-CABLE	1		
	87	GE40101-001A	PIN CAP	2		
	88	-----	DOOR SPRING	1	A	
	89	-----	CASSETTE LID	1	A	
	90	FSYH4036-035	SHEET	1	PET FOR R.COVER	
	92	QAL0165-001	FPC	1		
	93	FSYH4036-046	SHEET	1		
	94	FSYH4036-027	SPACER	1		
	96	FSYH4036-032	SHEET	1		
	97	FSKL4022-002	SHIELD BKT	1		

Cassette mechanism assembly and parts list

Block No. M 2 M M

MODEL : CDS-522VJ1

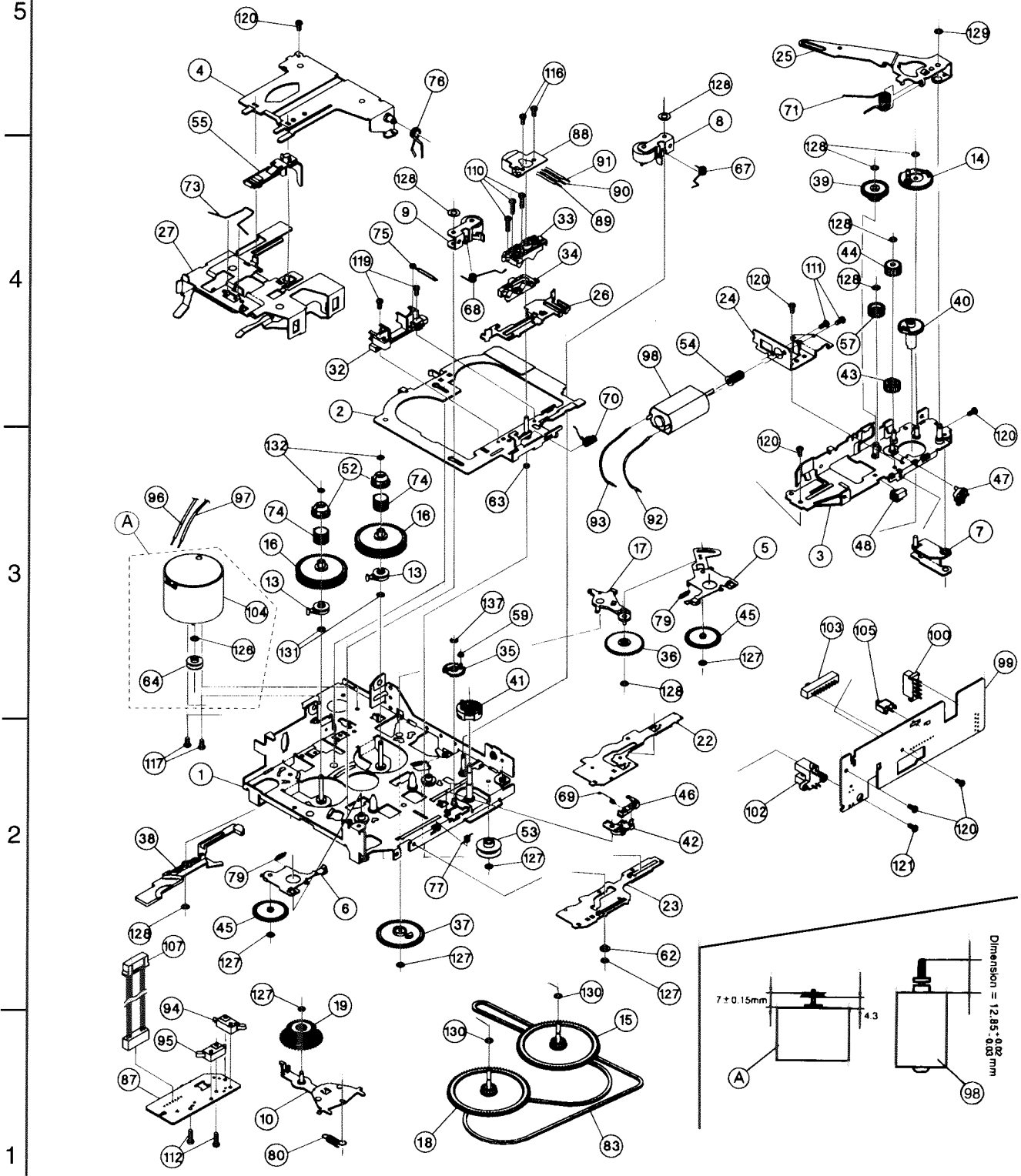

A

B

C

Parts list (Cassette mechanism)

Block No. M2MM

Item	Parts number	Parts name	Q'ty	Description	Area
A	100367057S-SA1	DC MOTOR ASS'Y	1		
1	1-0522-6001-02S	CHASSIS ASS'Y	1		
2	1-0522-6002-02S	HEAD PLATE ASSY	1		
3	1-0522-6003-11S	SUB CHASSIS ASY	1		
4	X-0522-1004S	HOLDER ARM ASSY	1		
5	X-0522-1006-02S	T.U.ARM(F)ASS'Y	1		
6	X-0522-1007S	T.U.ARM(R)ASS'Y	1		
7	X-0522-1010S	SET ARM ASS'Y	1		
8	X-0522-1019S	PINCH ARM(F)ASY	1		
9	X-0522-1020S	PINCH ARM(R)ASY	1		
10	X-0522-1022S	FR ARM ASS'Y	1		
13	X-0522-2008S	DETECT ARM ASSY	2		
14	X-0522-2010S	LOAD GEAR ASS'Y	1		
15	X-0522-2016-6S	FLYWHEEL ASY(FN	1		
16	X-0522-2018S	REEL TABLE ASSY	2		
17	X-0522-2020S	REDUCT.GEAR ARM	1		
18	X-0522-2021-6S	FLYWHEEL ASY(RN	1		
19	X-0052-2001S	F.R. GEAR ASS'Y	1		
22	1-0522-1008S	DIR.PLATE	1		
23	1-0522-1031S	FF/REW PLATE	1		
24	1-0522-1027S	MOTOR BKT	1		
25	1-0522-1013-30S	LOAD ARM	1		
26	1-0522-1014S	SHIFT CAM LINK	1		
27	1-0522-1017-50S	CASSETTE HOLDER	1		
29	1-0522-1016-02S	METAL DETECT LE	1		
32	1-0522-2001S	TAPE GUIDE	1		
33	1-0522-2002S	HEAD BKT	1		
34	1-0522-2003S	HEAD SHIFT CAM	1		
35	1-0522-2004-03S	SELECT GEAR	1		
36	1-0522-2005S	REDUCTION GEAR	1		
37	1-0522-2006S	DETECT GEAR	1		
38	1-0522-2007-50S	DETECTOR	1		
39	1-0522-2009S	WORM GEAR	1		
40	1-0522-2011S	MODE GEAR	1		
41	1-0522-2012S	MODE GEAR(2)	1		
42	1-0522-2013S	GEAR LATCH	1		
43	1-0522-2014S	IDLE GEAR(1)	1		
44	1-0522-2015S	IDLE GEAR(2)	1		
45	1-0522-2017S	TU GEAR	2		
46	1-0522-2019S	RACHET	1		
47	1-0522-2022S	SW ACTUATER	1		
48	1-0522-2024S	PWB STAY	1		
52	1-0052-2004S	REEL DRIVER	2		
53	1-0052-2006S	IDLE PULLEY	1		
54	1-0522-2023S	WORM	1		
55	1-0052-2032S	CATCH(K)	1		
57	1-0052-2041S	COUNTER GEAR	1		
59	1-0522-3005S	SELECT GEAR COL	1		

Parts list (Cassette mechanism)

Block No. M2MM

△	Item	Parts number	Parts name	Q'ty	Description	Area
	62	1-0052-3028S	H.B. ROLLER(L)	1		
	63	1-0052-3029S	H.B. ROLLER(S)	1		
	64	-----	MOTOR PULLEY	1		
	67	1-0522-4001S	PINCH ARM(F)SPG	1		
	68	1-0522-4002S	PINCH ARM(R)SPG	1		
	69	1-0522-4003S	GEAR LATCH SPG	1		
	70	1-0522-4004S	HEAD SPRING	1		
	71	1-0522-4006S	LOAD ARM SPG	1		
	73	1-0522-4008S	CATCH SPRING	1		
	74	1-0522-4010S	REEL DRIVER SPG	2		
	75	1-0522-4011S	DASH SPRING	1		
	76	1-0522-4014S	HOLDER ARM SPG	1		
	77	1-0522-4016S	HOLD SPRING	1		
	78	1-0522-4009S	METAL DETECT SP	1		
	79	1-0522-4017S	TU ARM SPRING	2		
	80	1-0522-4015S	FR ARM SPRING	1		
	83	1-0052-5022S	BELT	1		
	87	1-0522-7042S	REEL PWB	1		
	88	1-0522-7003S	2CH HEAD	1	P-7742-HG	
	89	1-0522-7004S	HEAD WIRE(A)	1		
	90	1-0522-7005S	HEAD WIRE(B)	1		
	91	1-0522-7006S	HEAD WIRE(C)	1		
	92	1-0522-7007-04S	SUB MOTOR WIRE	1	RED	
	93	1-0522-7008-04S	SUB MOTOR WIRE	1	BLACK	
	94	1-0522-7038S	LEAF SW	2	10920	
	95	1-0522-7039S	LEAF SW	1	11610	
	96	1-0522-7013S	MOTOR WIRE	1	RED	
	97	1-0522-7014S	MOTOR WIRE	1	BLACK	
	98	1-0522-7040S	SUB MOTOR	1	FF-050SK-10200	
	99	1-0522-7022-01S	HEAD PWB(JV)	1		
	100	1-0522-7024S	CONNECTOR 10P	1	TKC-F10X-K1	
	102	X-0052-7040S	PHOTO COUPLER	1		
	103	1-0036-7007-1S	SLIDE SWITCH	1	SLD-32-710S	
	104	-----	MOTOR ASS'Y	1	EG-520ED-3B	
	105	1-0056-7011S	SWITCH	1	SW-112-5	
	107	1-0052-7013S	JOINT WIRE (7P)	1		
	109	1-0522-5002S	SPECIAL SCREW	1		
	110	1-0522-5003S	AZIMUTH SCREW	3		
	111	1-0052-5023S	MOTOR SCREW	2	M2X2.5	
	112	1-0101-5006S	SCREW PLAIN	2	M1.7X7	
	116	1-0522-5005S	SPECIAL SCREW(2	2		
	117	2-1032-0022-C2S	MACHINE SCREW	2	M2X2.2	
	119	1-0522-5006S	SPECIAL SCREW(3	2		
	120	2-1332-0030-C1S	SCREW	6	M2X3	
	121	2-1382-0050-C2S	PLAIN	1	M2X5	
	126	-----	MYLAR WASHER	1		
	127	2-1812-0030-D2S	POLY WASHER(S)	6	1.2X3X0.25	
	128	2-1816-0032-D2S	POLY WASHER(S)	8	1.6X3.2X0.25	
	129	2-1817-5040-D8S	LMW-S	1	1.75X4X0.25	
	130	2-1816-0032-E8S	MYLAR WASHER(S)	2	1.6X3.2X0.35	
	131	2-1821-0040-D1S	POLY WASHER	2	2.1X4X0.25	
	132	1-0053-5005S	LMW-S	2	1.5X3.2X0.25	
	137	2-1711-5040-16S	E RING	1	1.5	

Electrical parts list

■ Electrical parts list (Main board)

Block No. 01

△	Item	Parts number	Parts name	Remarks	Area
	C 1	QERF1HM-104Z	E CAPACITOR	.10MF 20% 50V	
	C 2	NCB21EK-183X	C CAPACITOR		
	C 3	NCB21EK-183X	C CAPACITOR		
	C 4	QER41AM-227	E CAPACITOR	220MF 20% 10V	
	C 5	NDC21HJ-470X	C CAPACITOR		
	C 6	NCB21EK-563X	C CAPACITOR		
	C 7	NCB21HK-123X	C CAPACITOR		
	C 9	QER41AM-227	E CAPACITOR	220MF 20% 10V	
	C 10	NCB21HK-103X	C CAPACITOR		
	C 17	NCS21HJ-151X	C CAPACITOR		
	C 18	QERF1HM-474Z	E CAPACITOR	.47MF 20% 50V	
	C 20	NCB21HK-102X	C CAPACITOR		
	C 21	QEQF1HM-225Z	E CAPACITOR	2.2MF 20% 50V	
	C 24	NCB21EK-473X	C CAPACITOR		
	C 25	NCB21EK-104X	C CAPACITOR		
	C 26	NCB21EK-473X	C CAPACITOR		
	C 30	NDC21HJ-470X	C CAPACITOR		
	C 110	QER41HM-105	E CAPACITOR	1.0MF 20% 50V	
	C 111	QER41HM-105	E CAPACITOR	1.0MF 20% 50V	
	C 112	QER41HM-105	E CAPACITOR	1.0MF 20% 50V	
	C 113	QER41CM-106	E CAPACITOR	10MF 20% 16V	
	C 114	NCS21HJ-221X	C CAPACITOR		
	C 115	QERF1HM-225Z	E CAPACITOR	2.2MF 20% 50V	
	C 116	NCB21EK-823X	C CAPACITOR		
	C 117	QERF1HM-225Z	E CAPACITOR	2.2MF 20% 50V	
	C 118	QERF1HM-225Z	E CAPACITOR	2.2MF 20% 50V	
	C 119	QERF1HM-225Z	E CAPACITOR	2.2MF 20% 50V	
	C 120	QERF1HM-225Z	E CAPACITOR	2.2MF 20% 50V	
	C 121	QER41AM-107	E CAPACITOR	100MF 20% 10V	
	C 122	QER41AM-107	E CAPACITOR	100MF 20% 10V	
	C 123	QERF1CM-226Z	E CAPACITOR	22MF 20% 16V	
	C 124	QER41AM-107	E CAPACITOR	100MF 20% 10V	
	C 125	NCB21HK-152X	C CAPACITOR		
	C 126	NCB21HK-152X	C CAPACITOR		
	C 127	QER41HM-105	E CAPACITOR	1.0MF 20% 50V	
	C 128	QER41HM-105	E CAPACITOR	1.0MF 20% 50V	
	C 129	QER41CM-106	E CAPACITOR	10MF 20% 16V	
	C 130	NCB21EK-104X	C CAPACITOR		
	C 131	NCS21HJ-101X	C CAPACITOR		
	C 132	NCS21HJ-101X	C CAPACITOR		
	C 133	NCS21HJ-101X	C CAPACITOR		
	C 134	NCS21HJ-101X	C CAPACITOR		
	C 135	NCB21EK-333X	C CAPACITOR		
	C 136	QERF1CM-226Z	E CAPACITOR	22MF 20% 16V	
	C 137	NCB21EK-103X	C CAPACITOR		
	C 138	QER41HM-105	E CAPACITOR	1.0MF 20% 50V	
	C 139	QERF1EM-475Z	E CAPACITOR	4.7MF 20% 25V	
	C 140	QERF1EM-475Z	E CAPACITOR	4.7MF 20% 25V	
	C 141	QER41HM-105	E CAPACITOR	1.0MF 20% 50V	
	C 142	QER41HM-105	E CAPACITOR	1.0MF 20% 50V	
	C 143	NCS21HJ-471X	C CAPACITOR		
	C 144	NCS21HJ-471X	C CAPACITOR		
	C 151	QER41HM-105	E CAPACITOR	1.0MF 20% 50V	
	C 153	QER41HM-105	E CAPACITOR	1.0MF 20% 50V	
	C 161	NCB21HK-682X	C CAPACITOR		
	C 162	NCS21HJ-471X	C CAPACITOR		
	C 164	NCB21EK-103X	C CAPACITOR		
	C 165	NCB21EK-683X	C CAPACITOR		
	C 166	NCB21EK-683X	C CAPACITOR		
	C 167	NCB21EK-103X	C CAPACITOR		
	C 170	QERF1EM-475Z	E CAPACITOR	4.7MF 20% 25V	
	C 171	QERF1EM-475Z	E CAPACITOR	4.7MF 20% 25V	
	C 172	NCB21HK-183X	C CAPACITOR		

△	Item	Parts number	Parts name	Remarks	Area
	C 173	QER41CM-476	E CAPACITOR	47MF 20% 16V	
	C 175	QERF1EM-475Z	E CAPACITOR	4.7MF 20% 25V	
	C 176	QER41CM-106	E CAPACITOR	10MF 20% 16V	
	C 177	NCB21CK-224X	C CAPACITOR		
	C 178	NCB21HK-183X	C CAPACITOR		
	C 179	NCB21EK-473X	C CAPACITOR		
	C 180	NCB21EK-223X	C CAPACITOR		
	C 181	NCB21EK-473X	C CAPACITOR		
	C 182	NCB21EK-104X	C CAPACITOR		
	C 183	NCB21CK-224X	C CAPACITOR		
	C 184	QER41CM-106	E CAPACITOR	10MF 20% 16V	
	C 185	QERF1EM-475Z	E CAPACITOR	4.7MF 20% 25V	
	C 191	QER41CM-106	E CAPACITOR	10MF 20% 16V	
	C 192	QERF1CM-226Z	E CAPACITOR	22MF 20% 16V	
	C 198	NCB21EK-223X	C CAPACITOR		
	C 199	QER41AM-107	E CAPACITOR	100MF 20% 10V	
	C 210	QER41HM-105	E CAPACITOR	1.0MF 20% 50V	
	C 211	QER41HM-105	E CAPACITOR	1.0MF 20% 50V	
	C 212	QER41HM-105	E CAPACITOR	1.0MF 20% 50V	
	C 213	QER41CM-106	E CAPACITOR	10MF 20% 16V	
	C 214	NCS21HJ-221X	C CAPACITOR		
	C 215	QERF1HM-225Z	E CAPACITOR	2.2MF 20% 50V	
	C 216	NCB21EK-823X	C CAPACITOR		
	C 217	QER61HM-225Z	E CAPACITOR	2.2MF 20% 50V	
	C 218	QERF1HM-225Z	E CAPACITOR	2.2MF 20% 50V	
	C 219	QERF1HM-225Z	E CAPACITOR	2.2MF 20% 50V	
	C 220	QERF1HM-225Z	E CAPACITOR	2.2MF 20% 50V	
	C 221	QER41AM-107	E CAPACITOR	100MF 20% 10V	
	C 222	QER41AM-107	E CAPACITOR	100MF 20% 10V	
	C 223	QERF1CM-226Z	E CAPACITOR	22MF 20% 16V	
	C 224	QER41AM-107	E CAPACITOR	100MF 20% 10V	
	C 225	NCB21HK-152X	C CAPACITOR		
	C 226	NCB21HK-152X	C CAPACITOR		
	C 227	QER41HM-105	E CAPACITOR	1.0MF 20% 50V	
	C 228	QER41HM-105	E CAPACITOR	1.0MF 20% 50V	
	C 229	QER41CM-106	E CAPACITOR	10MF 20% 16V	
	C 231	NCS21HJ-101X	C CAPACITOR		
	C 232	NCS21HJ-101X	C CAPACITOR		
	C 233	NCS21HJ-101X	C CAPACITOR		
	C 234	NCS21HJ-101X	C CAPACITOR		
	C 235	NCB21EK-333X	C CAPACITOR		
	C 236	NCB21HK-333X	C CAPACITOR		
	C 237	NCB21EK-103X	C CAPACITOR		
	C 238	QER41HM-105	E CAPACITOR	1.0MF 20% 50V	
	C 239	QERF1EM-475Z	E CAPACITOR	4.7MF 20% 25V	
	C 240	QERF1EM-475Z	E CAPACITOR	4.7MF 20% 25V	
	C 241	QER41HM-105	E CAPACITOR	1.0MF 20% 50V	
	C 242	QER41HM-105	E CAPACITOR	1.0MF 20% 50V	
	C 243	NCS21HJ-471X	C CAPACITOR		
	C 244	NCS21HJ-471X	C CAPACITOR		
	C 251	QER41HM-105	E CAPACITOR	1.0MF 20% 50V	
	C 253	QER41HM-105	E CAPACITOR	1.0MF 20% 50V	
	C 261	NCB21HK-682X	C CAPACITOR		
	C 262	NCS21HJ-471X	C CAPACITOR		
	C 291	QER41CM-106	E CAPACITOR	10MF 20% 16V	
	C 292	QERF1CM-226Z	E CAPACITOR	22MF 20% 16V	
	C 401	NCB21EK-473X	C CAPACITOR		
	C 402	QERF1CM-226Z	E CAPACITOR	22MF 20% 16V	
	C 403	QERF1HM-224Z	E CAPACITOR	22MF 20% 50V	
	C 404	QER41HM-105	E CAPACITOR	1.0MF 20% 50V	
	C 411	QERF1HM-104Z	E CAPACITOR	.10MF 20% 50V	
	C 701	NDC21HJ-270X	C CAPACITOR		
	C 702	NDC21HJ-270X	C CAPACITOR		

■ Electrical parts list (Main board)

Block No. 01

▲	Item	Parts number	Parts name	Remarks	Area	▲	Item	Parts number	Parts name	Remarks	Area
	C 703	NCB21EK-104X	C CAPACITOR				D 6	MTZJ9.1C-T1	ZENER DIODE		
	C 704	NCB21EK-104X	C CAPACITOR				D 131	CRS03-W	SB DIODE		
	C 706	NCB21EK-473X	C CAPACITOR				D 132	CRS03-W	SB DIODE		
	C 707	NCB21EK-104X	C CAPACITOR				D 133	CRS03-W	SB DIODE		
	C 708	QER41AM-227	E CAPACITOR	220MF 20% 10V			D 134	CRS03-W	SB DIODE		
	C 709	QERF0JM-107Z	E CAPACITOR	100MF 20% 6.3V			D 231	CRS03-W	SB DIODE		
	C 710	NCB21HK-102X	C CAPACITOR				D 232	CRS03-W	SB DIODE		
	C 711	NCB21EK-104X	C CAPACITOR				D 233	CRS03-W	SB DIODE		
	C 751	NCB21EK-473X	C CAPACITOR				D 234	CRS03-W	SB DIODE		
	C 761	NCB21EK-223X	C CAPACITOR				D 401	1SS133-T1	SI DIODE I/M		
	C 762	NCS21HJ-561X	C CAPACITOR				D 402	1SS133-T1	SI DIODE I/M		
	C 763	QERF1HM-225Z	E CAPACITOR	2.2MF 20% 50V			D 403	DAN202K-X	D.TRANSISTOR		
	C 764	NDC21HJ-820X	C CAPACITOR				D 701	MTZJ5.6B-T1	ZENER DIODE		
	C 765	NDC21HJ-470X	C CAPACITOR				D 702	MTZJ5.6B-T1	ZENER DIODE		
	C 766	QER41CM-476	E CAPACITOR	47MF 20% 16V			D 703	MTZJ5.6B-T1	ZENER DIODE		
	C 767	NCB21HK-103X	C CAPACITOR				D 704	MTZJ5.6B-T1	ZENER DIODE		
	C 781	NCB21HK-183X	C CAPACITOR				D 705	MTZJ5.6B-T1	ZENER DIODE		
	C 782	NCB21EK-393X	C CAPACITOR				D 706	MTZJ5.6B-T1	ZENER DIODE		
	C 783	NCB21EK-393X	C CAPACITOR				D 707	MTZJ5.6B-T1	ZENER DIODE		
	C 784	NCB21EK-393X	C CAPACITOR				D 708	MTZJ5.6B-T1	ZENER DIODE		
	C 785	NCB21EK-393X	C CAPACITOR				D 709	MTZJ5.6B-T1	ZENER DIODE		
	C 786	NCB21HK-122X	C CAPACITOR				D 931	DAP202K-X	D.TRANSISTOR		
	C 787	QER41CM-106	E CAPACITOR	10MF 20% 16V			D 932	DAP202K-X	D.TRANSISTOR		
	C 788	QER41CM-476	E CAPACITOR	47MF 20% 16V			D 933	DAP202K-X	D.TRANSISTOR		
	C 911	QER41AM-107	E CAPACITOR	100MF 20% 10V			D 951	1SS133-T1	SI DIODE I/M		
	C 912	QER41AM-107	E CAPACITOR	100MF 20% 10V			D 961	1N5401-TU-15	DIODE		
	C 914	NCB21EK-104X	C CAPACITOR				D 963	DAP202K-X	D.TRANSISTOR		
	C 915	QER41CM-476	E CAPACITOR	47MF 20% 16V			D 965	CRS01-W	SB DIODE		
	C 916	QERF1HM-474Z	E CAPACITOR	47MF 20% 50V			D 978	MTZJ11C-T1	ZENER DIODE		
	C 917	QERF1EM-475Z	E CAPACITOR	4.7MF 20% 25V			D 979	MTZJ5.6B-T1	ZENER DIODE		
	C 918	QERF1EM-475Z	E CAPACITOR	4.7MF 20% 25V			D 980	CRS01-W	SB DIODE		
	C 919	QERF1HM-474Z	E CAPACITOR	47MF 20% 50V			D 981	DAP202K-X	D.TRANSISTOR		
	C 920	QER41CM-476	E CAPACITOR	47MF 20% 16V			D 982	CRS01-W	SB DIODE		
	C 931	NCB21CK-224X	C CAPACITOR				D 983	DAP202K-X	D.TRANSISTOR		
	C 932	NCB21CK-224X	C CAPACITOR				D 984	DAP202K-X	D.TRANSISTOR		
	C 941	NCB21EK-104X	C CAPACITOR				IC121	BA3220FV-X	IC		
	C 943	NCB21EK-104X	C CAPACITOR				IC171	M5282FP-XE	IC		
	C 944	NCB21EK-104X	C CAPACITOR				IC172	NJM4565M-WE	IC		
	C 946	NCB21EK-104X	C CAPACITOR				IC173	BU4066BCF-X	IC		
	C 947	NCB21EK-104X	C CAPACITOR				IC191	NJM4565M-WE	IC		
	C 961	QETB1CM-228	E CAPACITOR	2200MF 20% 16V			IC221	BA3220FV-X	IC		
	C 962	QER41CM-106	E CAPACITOR	10MF 20% 16V			IC701	UPD178018AGC543	I.C(MICRO-COMP)		
	C 963	QERF1HM-104Z	E CAPACITOR	10MF 20% 50V			IC751	HD74HC126FP-X	IC		
	C 964	QETN0JM-228Z	E CAPACITOR	2200MF 20% 6.3V			IC761	SAA6579T-X	IC		
	C 965	QER41AM-227	E CAPACITOR	220MF 20% 10V			IC781	NJM2100M-WE	IC		
	C 966	QERF1CM-107Z	E CAPACITOR	100MF 20% 16V			IC911	LC75385NE-RUJ	IC		
	C 967	QER41HM-105	E CAPACITOR	1.0MF 20% 50V			IC921	BA3880FS-X	IC		
	C 968	NCB21EK-473X	C CAPACITOR				IC941	TDA8568Q/N3	IC		
	C 969	NCB21EK-473X	C CAPACITOR				IC961	BA4901A-V3	IC		
	C 970	NCB21EK-473X	C CAPACITOR				J 1	QNZ0009-001	CAR ANT JACK		
	C 977	QERF1CM-107Z	E CAPACITOR	100MF 20% 16V			J 751	QNZ00095-001	CONNECTOR		
	C 978	QER41CM-106	E CAPACITOR	10MF 20% 16V			J 921	OGA2006C1-04	CONNECTOR		
	C 979	QERF0JM-476Z	E CAPACITOR	47MF 20% 6.3V			J 931	QNN0176-001	PIN JACK		
	C 980	QER41AM-227	E CAPACITOR	220MF 20% 10V			L 1	QLL244J-4R7Z	INDUCTOR		
	C 983	NCB21EK-104X	C CAPACITOR				L 701	QLL244J-470Z	INDUCTOR		
	C 984	NCB21EK-473X	C CAPACITOR				L 702	QLL244J-470Z	INDUCTOR		
	CJ701	QNZ0007-002	CAR CONNECTOR				L 961	QQR0703-001	CHOKE COIL		
	CP501	QGB1214J1-18S	CONNECTOR				PL701	QLL0033-001	LAMP		
	CP961	QNZ0112-001	CAR CONNECTOR				Q 1	DTC114EKA-X	TRANSISTOR		
	D 1	1SS133-T1	SI DIODE I/M				Q 2	DTC114EKA-X	TRANSISTOR		
	D 2	1SS133-T1	SI DIODE I/M				Q 3	2SC2412K/R/-X	TRANSISTOR		
	D 3	DAN202K-X	D TRANSISTOR				Q 4	DTA114EKA-X	DIGITAL TRANSIS		
	D 5	1SS133-T1	SI DIODE I/M				Q 5	2SA1037AK/RS/-X	TRANSISTOR		

KS-FX950R

■ Electrical parts list (Main board)

Block No. 01

▲	Item	Parts number	Parts name	Remarks	Area
	Q 6	2SA1037AK/RS/-X	TRANSISTOR		
	Q 7	2SC3661-X	TRANSISTOR		
	Q 10	2SC3661-X	TRANSISTOR		
	Q 11	2SC2412K/R/-X	TRANSISTOR		
	Q 12	2SC2412K/R/-X	TRANSISTOR		
	Q 14	DTC114EKA-X	TRANSISTOR		
	Q 130	DTC114EKA-X	TRANSISTOR		
	Q 131	2SD1048/6-7/-X	TRANSISTOR		
	Q 132	2SD1048/6-7/-X	TRANSISTOR		
	Q 151	2SC2412K/R/-X	TRANSISTOR		
	Q 171	2SD1048/6-7/-X	TRANSISTOR		
	Q 181	DTC114EKA-X	TRANSISTOR		
	Q 182	DTC114EKA-X	TRANSISTOR		
	Q 231	2SD1048/6-7/-X	TRANSISTOR		
	Q 232	2SD1048/6-7/-X	TRANSISTOR		
	Q 251	2SC2412K/R/-X	TRANSISTOR		
	Q 401	2SC2412K/R/-X	TRANSISTOR		
	Q 411	DTC114EKA-X	TRANSISTOR		
	Q 914	DTC114EKA-X	TRANSISTOR		
	Q 951	DTA114EKA-X	DIGITAL TRANSIS		
	Q 961	2SA1706/ST-T	TRANSISTOR		
	Q 963	2SA1037AK/RS/-X	TRANSISTOR		
	Q 964	DTC114EKA-X	TRANSISTOR		
	Q 965	UN2211-X	TRANSISTOR		
	Q 966	2SA1706/ST-T	TRANSISTOR		
	Q 967	DTC114EKA-X	TRANSISTOR		
	Q 968	2SA1706/ST-T	TRANSISTOR		
	Q 969	2SA1037AK/RS/-X	TRANSISTOR		
	Q 978	DTC114EKA-X	TRANSISTOR		
	Q 979	DTA114EKA-X	DIGITAL TRANSIS		
	Q 980	DTA114EKA-X	DIGITAL TRANSIS		
	Q 981	DTA114EKA-X	DIGITAL TRANSIS		
	Q 992	2SC2412K/R/-X	TRANSISTOR		
	R 1	NRSA02J-0R0X	MG RESISTOR		
	R 3	NRSA02J-472X	MG RESISTOR		
	R 4	NRSA02J-473X	MG RESISTOR		
	R 5	NRSA02J-332X	MG RESISTOR		
	R 6	NRSA02J-223X	MG RESISTOR		
	R 7	NRSA02J-473X	MG RESISTOR		
	R 8	NRSA02J-472X	MG RESISTOR		
	R 9	NRSA02J-102X	MG RESISTOR		
	R 10	NRSA02J-392X	MG RESISTOR		
	R 12	NRSA02J-102X	MG RESISTOR		
	R 13	NRSA02J-0R0X	MG RESISTOR		
	R 14	NRS181J-471X	MG RESISTOR		
	R 15	NRSA02J-0R0X	MG RESISTOR		
	R 16	NRS181J-0R0X	MG RESISTOR		
	R 24	NRSA02J-102X	MG RESISTOR		
	R 25	NRSA02J-102X	MG RESISTOR		
	R 26	NRSA02J-103X	MG RESISTOR		
	R 27	NRSA02J-102X	MG RESISTOR		
	R 29	NRSA02J-152X	MG RESISTOR		
	R 30	NRS181J-120X	MG RESISTOR		
	R 32	NRSA02J-0R0X	MG RESISTOR		
	R 113	NRSA02J-683X	MG RESISTOR		
	R 114	NRSA02J-472X	MG RESISTOR		
	R 115	NRSA02J-224X	MG RESISTOR		
	R 118	NRSA02J-224X	MG RESISTOR		
	R 119	NRSA02J-105X	MG RESISTOR		
	R 123	NRSA02J-223X	MG RESISTOR		
	R 124	NRSA02J-223X	MG RESISTOR		
	R 125	NRSA02J-333X	MG RESISTOR		
	R 126	NRSA02J-333X	MG RESISTOR		

▲	Item	Parts number	Parts name	Remarks	Area
	R 130	NRSA02J-472X	MG RESISTOR		
	R 131	NRSA02J-473X	MG RESISTOR		
	R 132	NRSA02J-222X	MG RESISTOR		
	R 133	NRSA02J-222X	MG RESISTOR		
	R 135	NRSA02J-101X	MG RESISTOR		
	R 136	NRSA02J-102X	MG RESISTOR		
	R 137	NRSA02J-101X	MG RESISTOR		
	R 138	NRSA02J-102X	MG RESISTOR		
	R 141	NRSA02J-823X	MG RESISTOR		
	R 142	NRSA02J-823X	MG RESISTOR		
	R 143	NRSA02J-103X	MG RESISTOR		
	R 144	NRSA02J-103X	MG RESISTOR		
	R 151	NRSA02J-242X	MG RESISTOR		
	R 152	NRSA02J-223X	MG RESISTOR		
	R 153	NRSA02J-472X	MG RESISTOR		
	R 171	NRSA02J-393X	MG RESISTOR		
	R 172	NRSA02J-223X	MG RESISTOR		
	R 173	NRSA02J-473X	MG RESISTOR		
	R 174	NRSA02J-473X	MG RESISTOR		
	R 175	NRSA02J-223X	MG RESISTOR		
	R 176	NRSA02J-473X	MG RESISTOR		
	R 177	NRSA02J-103X	MG RESISTOR		
	R 178	NRSA02J-203X	MG RESISTOR		
	R 179	NRSA02J-203X	MG RESISTOR		
	R 180	NRSA02J-473X	MG RESISTOR		
	R 181	NRSA02J-473X	MG RESISTOR		
	R 182	NRSA02J-471X	MG RESISTOR		
	R 183	NRSA02J-101X	MG RESISTOR		
	R 184	NRSA02J-101X	MG RESISTOR		
	R 185	NRSA02J-473X	MG RESISTOR		
	R 188	NRSA02J-225X	MG RESISTOR		
	R 189	NRSA02J-225X	MG RESISTOR		
	R 191	NRSA02J-104X	MG RESISTOR		
	R 192	NRSA02J-103X	MG RESISTOR		
	R 193	NRSA02J-103X	MG RESISTOR		
	R 194	NRSA02J-103X	MG RESISTOR		
	R 195	NRSA02J-102X	MG RESISTOR		
	R 196	NRSA02J-103X	MG RESISTOR		
	R 197	NRSA02J-471X	MG RESISTOR		
	R 198	NRSA02J-472X	MG RESISTOR		
	R 199	NRSA02J-472X	MG RESISTOR		
	R 213	NRSA02J-683X	MG RESISTOR		
	R 214	NRSA02J-472X	MG RESISTOR		
	R 215	NRSA02J-224X	MG RESISTOR		
	R 218	NRSA02J-224X	MG RESISTOR		
	R 219	NRSA02J-105X	MG RESISTOR		
	R 220	NRSA02J-105X	MG RESISTOR		
	R 223	NRSA02J-223X	MG RESISTOR		
	R 224	NRSA02J-223X	MG RESISTOR		
	R 225	NRSA02J-333X	MG RESISTOR		
	R 226	NRSA02J-333X	MG RESISTOR		
	R 232	NRSA02J-222X	MG RESISTOR		
	R 233	NRSA02J-222X	MG RESISTOR		
	R 235	NRSA02J-101X	MG RESISTOR		
	R 236	NRSA02J-102X	MG RESISTOR		
	R 237	NRSA02J-101X	MG RESISTOR		
	R 238	NRSA02J-102X	MG RESISTOR		
	R 241	NRSA02J-823X	MG RESISTOR		
	R 242	NRSA02J-823X	MG RESISTOR		
	R 243	NRSA02J-103X	MG RESISTOR		
	R 244	NRSA02J-103X	MG RESISTOR		
	R 251	NRSA02J-242X	MG RESISTOR		
	R 252	NRSA02J-223X	MG RESISTOR		

■ Electrical parts list (Main board)

Block No. 01

▲	Item	Parts number	Parts name	Remarks	Area
	R 253	NRSA02J-472X	MG RESISTOR		
	R 288	NRSA02J-225X	MG RESISTOR		
	R 289	NRSA02J-225X	MG RESISTOR		
	R 291	NRSA02J-104X	MG RESISTOR		
	R 292	NRSA02J-103X	MG RESISTOR		
	R 293	NRSA02J-103X	MG RESISTOR		
	R 294	NRSA02J-103X	MG RESISTOR		
	R 295	NRSA02J-102X	MG RESISTOR		
	R 296	NRSA02J-103X	MG RESISTOR		
	R 401	NRSA02J-123X	MG RESISTOR		
	R 402	NRSA02J-102X	MG RESISTOR		
	R 403	NRSA02J-274X	MG RESISTOR		
	R 404	NRSA02J-471X	MG RESISTOR		
	R 405	NRSA02J-184X	MG RESISTOR		
	R 406	NRSA02J-223X	MG RESISTOR		
	R 407	NRSA02J-473X	MG RESISTOR		
	R 411	NRSA02J-102X	MG RESISTOR		
	R 412	NRSA02J-222X	MG RESISTOR		
	R 700	NRSA02J-102X	MG RESISTOR		
	R 702	NRSA02J-271X	MG RESISTOR		
	R 703	NRSA02J-271X	MG RESISTOR		
	R 704	NRSA02J-271X	MG RESISTOR		
	R 705	NRSA02J-103X	MG RESISTOR		
	R 706	NRSA02J-473X	MG RESISTOR		
	R 708	NRSA02J-104X	MG RESISTOR		
	R 709	NRSA02J-104X	MG RESISTOR		
	R 710	NRSA02J-103X	MG RESISTOR		
	R 711	NRSA02J-391X	MG RESISTOR		
	R 712	NRSA02J-103X	MG RESISTOR		
	R 714	NRSA02J-103X	MG RESISTOR		
	R 715	NRSA02J-103X	MG RESISTOR		
	R 716	NRSA02J-103X	MG RESISTOR		
	R 717	NRSA02J-103X	MG RESISTOR		
	R 718	NRSA02J-472X	MG RESISTOR		
	R 719	NRSA02J-472X	MG RESISTOR		
	R 720	NRSA02J-472X	MG RESISTOR		
	R 721	NRSA02J-472X	MG RESISTOR		
	R 722	NRSA02J-472X	MG RESISTOR		
	R 723	NRSA02J-472X	MG RESISTOR		
	R 724	NRSA02J-472X	MG RESISTOR		
	R 725	NRSA02J-472X	MG RESISTOR		
	R 726	NRSA02J-472X	MG RESISTOR		
	R 727	NRSA02J-472X	MG RESISTOR		
	R 728	NRSA02J-473X	MG RESISTOR		
	R 729	NRSA02J-473X	MG RESISTOR		
	R 731	NRSA02J-473X	MG RESISTOR		
	R 732	NRSA02J-472X	MG RESISTOR		
	R 733	NRSA02J-472X	MG RESISTOR		
	R 734	NRSA02J-472X	MG RESISTOR		
	R 735	NRSA02J-473X	MG RESISTOR		
	R 736	NRSA02J-473X	MG RESISTOR		
	R 737	NRSA02J-473X	MG RESISTOR		
	R 738	NRSA02J-473X	MG RESISTOR		
	R 739	NRSA02J-473X	MG RESISTOR		
	R 740	NRSA02J-473X	MG RESISTOR		
	R 741	NRSA02J-473X	MG RESISTOR		
	R 745	NRSA02J-103X	MG RESISTOR		
	R 746	NRSA02J-473X	MG RESISTOR		
	R 747	NRSA02J-103X	MG RESISTOR		
	R 748	NRSA02J-103X	MG RESISTOR		
	R 750	NRSA02J-473X	MG RESISTOR		
	R 751	NRSA02J-104X	MG RESISTOR		
	R 752	NRSA02J-334X	MG RESISTOR		

▲	Item	Parts number	Parts name	Remarks	Area
	R 753	NRSA02J-223X	MG RESISTOR		
	R 754	NRSA02J-101X	MG RESISTOR		
	R 755	NRSA02J-103X	MG RESISTOR		
	R 756	NRSA02J-104X	MG RESISTOR		
	R 757	NRSA02J-104X	MG RESISTOR		
	R 758	NRSA02J-101X	MG RESISTOR		
	R 759	NRSA02J-334X	MG RESISTOR		
	R 761	NRSA02J-222X	MG RESISTOR		
	R 762	NRSA02J-222X	MG RESISTOR		
	R 763	NRSA02J-222X	MG RESISTOR		
	R 764	NRS181J-103X	MG RESISTOR		
	R 773	NRSA02J-104X	MG RESISTOR		
	R 780	NRSA02J-820X	MG RESISTOR		
	R 781	QRZ0125-102X	C RESISTOR	1.0K 1/W	
	R 782	NRSA02J-822X	MG RESISTOR		
	R 783	NRSA02J-223X	MG RESISTOR		
	R 784	NRSA02J-822X	MG RESISTOR		
	R 785	NRSA02J-223X	MG RESISTOR		
	R 786	NRSA02J-153X	MG RESISTOR		
	R 787	NRSA02J-472X	MG RESISTOR		
	R 788	NRSA02J-223X	MG RESISTOR		
	R 789	NRSA02J-223X	MG RESISTOR		
	R 790	NRSA02J-103X	MG RESISTOR		
	R 791	NRSA02J-333X	MG RESISTOR		
	R 911	NRSA02J-271X	MG RESISTOR		
	R 912	NRSA02J-271X	MG RESISTOR		
	R 913	NRSA02J-271X	MG RESISTOR		
	R 914	NRSA02J-392X	MG RESISTOR		
	R 915	NRSA02J-512X	MG RESISTOR		
	R 933	NRS181J-222X	MG RESISTOR		
	R 960	NRSA02J-223X	MG RESISTOR		
	R 961	QRZ0125-470X	C RESISTOR	47 1/W	
	R 962	NRSA02J-103X	MG RESISTOR		
	R 963	NRSA02J-472X	MG RESISTOR		
	R 966	NRSA02J-473X	MG RESISTOR		
	R 967	NRSA02J-222X	MG RESISTOR		
	R 968	NRSA02J-102X	MG RESISTOR		
	R 969	NRSA02J-473X	MG RESISTOR		
	R 970	NRS181J-4R7X	MG RESISTOR		
	R 971	NRS181J-4R7X	MG RESISTOR		
	R 972	NRS181J-4R7X	MG RESISTOR		
	R 973	NRS181J-332X	MG RESISTOR		
	R 974	NRSA02J-123X	MG RESISTOR		
	R 975	NRSA02J-273X	MG RESISTOR		
	R 976	NRS181J-332X	MG RESISTOR		
	R 977	NRSA02J-472X	MG RESISTOR		
	R 978	NRS181J-332X	MG RESISTOR		
	R 979	NRSA02J-103X	MG RESISTOR		
	R 980	NRSA02J-183X	MG RESISTOR		
	R 981	NRSA02J-152X	MG RESISTOR		
	R 982	NRSA02J-102X	MG RESISTOR		
	R 983	NRSA02J-393X	MG RESISTOR		
	R 987	NRSA02J-0R0X	MG RESISTOR		
	R 993	NRSA02J-473X	MG RESISTOR		
	R 995	NRSA02J-103X	MG RESISTOR		
	R 996	NRSA02J-102X	MG RESISTOR		
	R 997	NRSA02J-103X	MG RESISTOR		
	S 701	QSW0451-001	DETECT SW		
	S 702	QSW0451-001	DETECT SW		
	TU 1	QAU0103-002	TUNER		
	X 701	QAX0406-001Z	CRYSTAL		
	X 761	QAX0263-001Z	CRYSTAL		

KS-FX950R

■ Electrical parts list (Mecha control board) Block No. 02

△	Item	Parts number	Parts name	Remarks	Area
	C 101	NCB21HK-471X	C CAPACITOR		
	C 102	QFV61HJ-103Z	TF CAPACITOR	.010MF 5% 50V	
	C 103	QEQ61HM-105Z	NP E CAPACITOR	1.0MF 20% 50V	
	C 104	QFV61HJ-104Z	TF CAPACITOR	.10MF 5% 50V	
	C 105	NDC21HJ-101X	C CAPACITOR		
	C 201	NCB21HK-471X	C CAPACITOR		
	C 202	QFV61HJ-103Z	TF CAPACITOR	.010MF 5% 50V	
	C 203	QEQF1HM-105Z	NP E CAPACITOR	1.0MF 20% 50V	
	C 204	QFV61HJ-104Z	TF CAPACITOR	.10MF 5% 50V	
	C 205	NDC21HJ-101X	C CAPACITOR		
	C 501	NCB21HK-103X	C CAPACITOR		
	C 502	NCB21EK-104X	C CAPACITOR		
	C 503	QEK41CM-106	E CAPACITOR	10MF 20% 16V	
	C 901	QER61CM-226Z	E CAPACITOR	22MF 20% 16V	
	C 902	NDC21HJ-221X	C CAPACITOR		
	C 903	QEK41HM-474	E CAPACITOR	.47MF 20% 50V	
	C 904	NCB21HK-103X	C CAPACITOR		
	C 905	NCB21EK-104X	C CAPACITOR		
	C 906	QEKJ1CM-226Z	E CAPACITOR	22MF 20% 16V	
	CJ501	QGB1214K1-18S	CONNECTOR		
	CJ503	QGB1214K1-10S	CONNECTOR		
	CP502	QGA2001F1-07	CONNECTOR		
	D 501	DSK10C-T1	DIODE		
	D 502	MA3036/L/-X	ZENER DIODE		
	D 503	MA3075/M/-X	ZENER DIODE		
	IC501	LB1641	IC		
	IC901	CXA2510AQ	IC		
	Q 501	2SB1322/RS/-T	TRANSISTOR		
	Q 502	DTC114EKA-X	TRANSISTOR		
	Q 503	DTC114EKA-X	TRANSISTOR		
	R 101	NRSA02J-104X	MG RESISTOR		
	R 102	NRSA02J-183X	MG RESISTOR		
	R 103	NRSA02J-123X	MG RESISTOR		
	R 104	NRSA02J-304X	MG RESISTOR		
	R 105	NRSA02J-181X	MG RESISTOR		
	R 108	NRS181J-102X	MG RESISTOR		
	R 201	NRSA02J-104X	MG RESISTOR		
	R 202	NRSA02J-183X	MG RESISTOR		
	R 203	NRSA02J-123X	MG RESISTOR		
	R 204	NRSA02J-304X	MG RESISTOR		
	R 205	NRS181J-181X	MG RESISTOR		
	R 208	NRSA02J-102X	MG RESISTOR		
	R 501	NRS181J-473X	MG RESISTOR		
	R 502	NRS181J-332X	MG RESISTOR		
	R 503	NRSA02J-332X	MG RESISTOR		
	R 504	QRT036J-8R2	OMF RESISTOR	8.2 5% 1/3W	
	R 505	NRS181J-330X	MG RESISTOR		
	R 506	NRSA02J-222X	MG RESISTOR		
	R 901	NRS181J-101X	MG RESISTOR		
	R 902	NRSA02J-392X	MG RESISTOR		
	R 903	NRSA02J-223X	MG RESISTOR		
	R 904	NRSA02J-125X	MG RESISTOR		
	R 905	NRSA02J-153X	MG RESISTOR		
	R 906	NRS181J-103X	MG RESISTOR		
	R 907	NRSA02J-183X	MG RESISTOR		
	VR101	QVP0006-333Z	SEMI.V.RESISTOR		
	VR201	QVP0006-333Z	SEMI.V.RESISTOR		

■ Electrical parts list (Switch board)

Block No. 03

△	Item	Parts number	Parts name	Remarks	Area
	C 601	NBE20JM-475X	TS E CAPACITOR		
	C 602	NCB21HK-103X	C CAPACITOR		
	C 603	NCS21HJ-221X	C CAPACITOR		
	C 604	NCB21CK-224X	C CAPACITOR		
	C 605	NCB21CK-224X	C CAPACITOR		
	C 606	NBE20JM-475X	TS E CAPACITOR		
	C 661	NCB21HK-473X	C CAPACITOR		
	CN711	QNZ0006-001	CAR CONNECTOR		
	D 601	SML-310LT/MN/-X	LED		
	D 602	SML-310FT/JKL/X	LED		
	D 603	SML-310FT/JKL/X	LED		
	D 604	SML-310FT/JKL/X	LED		
	D 605	SML-310FT/JKL/X	LED		
	D 606	SML-310FT/JKL/X	LED		
	D 607	SML-310FT/JKL/X	LED		
	D 608	SML-310FT/JKL/X	LED		
	D 609	SML-310FT/JKL/X	LED		
	D 610	SML-310FT/JKL/X	LED		
	D 611	SML-310FT/JKL/X	LED		
	D 612	SML-310FT/JKL/X	LED		
	D 613	SML-310FT/JKL/X	LED		
	D 614	SML-310FT/JKL/X	LED		
	D 615	SML-310FT/JKL/X	LED		
	D 616	SML-310FT/JKL/X	LED		
	D 617	SML-310FT/JKL/X	LED		
	D 618	SML-310FT/JKL/X	LED		
	D 619	SML-310FT/JKL/X	LED		
	D 620	SML-310FT/JKL/X	LED		
	D 621	SML-310FT/JKL/X	LED		
	D 622	SML-310FT/JKL/X	LED		
	D 623	SML-310FT/JKL/X	LED		
	D 624	LNJ912W8B-X	LED		
	D 625	SML-310FT/JKL/X	LED		
	D 626	SML-310FT/JKL/X	LED		
	D 627	SML-310FT/JKL/X	LED		
	D 628	SML-310FT/JKL/X	LED		
	D 641	NSPW310BS/B/	LED		
	D 642	NSPW310BS/B/	LED		
	D 643	NSPW310BS/B/	LED		
	D 651	MA3051/M/-X	ZENER DIODE		
	D 652	MA152WK-X	SI DIODE		
	D 653	MA152WA-X	DIODE		
	D 654	MA152WK-X	SI DIODE		
	D 655	MA152WA-X	DIODE		
	D 656	MA152WK-X	SI DIODE		
	D 657	MA3056/M/-X	ZENER DIODE		
	EN601	QSW0793-001	ROTARY ENCODER		
	IC601	LC75873NW	IC		
	IC602	RPM6938-SV4	IC		
	J 601	QNS0145-001	3.5 JACK		
	Q 641	2SB815/7/-X	TRANSISTOR		
	Q 642	UN2211-X	TRANSISTOR		
	R 601	NRSA02J-821X	MG RESISTOR		
	R 602	NRSA02J-821X	MG RESISTOR		
	R 603	NRSA02J-122X	MG RESISTOR		
	R 604	NRSA02J-182X	MG RESISTOR		
	R 605	NRSA02J-272X	MG RESISTOR		
	R 606	NRSA02J-392X	MG RESISTOR		
	R 607	NRSA02J-821X	MG RESISTOR		
	R 608	NRSA02J-821X	MG RESISTOR		
	R 609	NRSA02J-122X	MG RESISTOR		
	R 610	NRSA02J-182X	MG RESISTOR		
	R 611	NRSA02J-272X	MG RESISTOR		

△	Item	Parts number	Parts name	Remarks	Area
	R 612	NRSA02J-392X	MG RESISTOR		
	R 613	NRSA02J-821X	MG RESISTOR		
	R 614	NRSA02J-821X	MG RESISTOR		
	R 615	NRSA02J-122X	MG RESISTOR		
	R 616	NRSA02J-182X	MG RESISTOR		
	R 617	NRSA02J-272X	MG RESISTOR		
	R 620	NRS181J-561X	MG RESISTOR		
	R 621	NRS181J-271X	MG RESISTOR		
	R 622	NRS181J-271X	MG RESISTOR		
	R 623	NRS181J-271X	MG RESISTOR		
	R 624	NRS181J-271X	MG RESISTOR		
	R 625	NRS181J-431X	MG RESISTOR		
	R 626	NRS181J-431X	MG RESISTOR		
	R 627	NRS181J-431X	MG RESISTOR		
	R 628	NRS181J-431X	MG RESISTOR		
	R 629	NRS181J-431X	MG RESISTOR		
	R 630	NRS181J-182X	MG RESISTOR		
	R 631	NRS181J-271X	MG RESISTOR		
	R 641	NRS181J-431X	MG RESISTOR		
	R 642	NRS181J-431X	MG RESISTOR		
	R 643	NRS181J-431X	MG RESISTOR		
	R 644	NRS181J-471X	MG RESISTOR		
	R 645	NRSA02J-473X	MG RESISTOR		
	R 646	NRS181J-102X	MG RESISTOR		
	R 650	NRSA02J-101X	MG RESISTOR		
	R 651	NRSA02J-473X	MG RESISTOR		
	R 652	NRSA02J-473X	MG RESISTOR		
	R 653	NRS181J-102X	MG RESISTOR		
	R 654	NRSA02J-221X	MG RESISTOR		
	R 655	NRSA02J-394X	MG RESISTOR		
	R 656	NRSA02J-334X	MG RESISTOR		
	R 657	NRSA02J-103X	MG RESISTOR		
	R 658	NRSA02J-470X	MG RESISTOR		
	R 661	NRSA02J-332X	MG RESISTOR		
	R 662	NRSA02J-332X	MG RESISTOR		
	R 663	NRSA02J-332X	MG RESISTOR		
	R 664	NRSA02J-471X	MG RESISTOR		
	R 667	NRSA02J-0R0X	MG RESISTOR		
	R 668	NRSA02J-0R0X	MG RESISTOR		
	R 669	NRSA02J-103X	MG RESISTOR		
	R 670	NRSA02J-103X	MG RESISTOR		
	R 671	NRSA02J-103X	MG RESISTOR		
	S 601	NSW0066-001X	TACT SWITCH		
	S 602	NSW0066-001X	TACT SWITCH		
	S 603	NSW0066-001X	TACT SWITCH		
	S 604	NSW0066-001X	TACT SWITCH		
	S 605	NSW0066-001X	TACT SWITCH		
	S 606	NSW0066-001X	TACT SWITCH		
	S 607	NSW0066-001X	TACT SWITCH		
	S 608	NSW0066-001X	TACT SWITCH		
	S 609	NSW0066-001X	TACT SWITCH		
	S 610	NSW0066-001X	TACT SWITCH		
	S 611	NSW0066-001X	TACT SWITCH		
	S 612	NSW0066-001X	TACT SWITCH		
	S 613	NSW0066-001X	TACT SWITCH		
	S 614	NSW0066-001X	TACT SWITCH		
	S 615	NSW0066-001X	TACT SWITCH		
	S 616	NSW0066-001X	TACT SWITCH		
	S 617	NSW0066-001X	TACT SWITCH		
	S 618	NSW0066-001X	TACT SWITCH		
	S 619	NSW0066-001X	TACT SWITCH		
	S 620	NSW0066-001X	TACT SWITCH		

Packing materials and accessories parts list

Block No. M 3 M M

Block No. M 4 M M

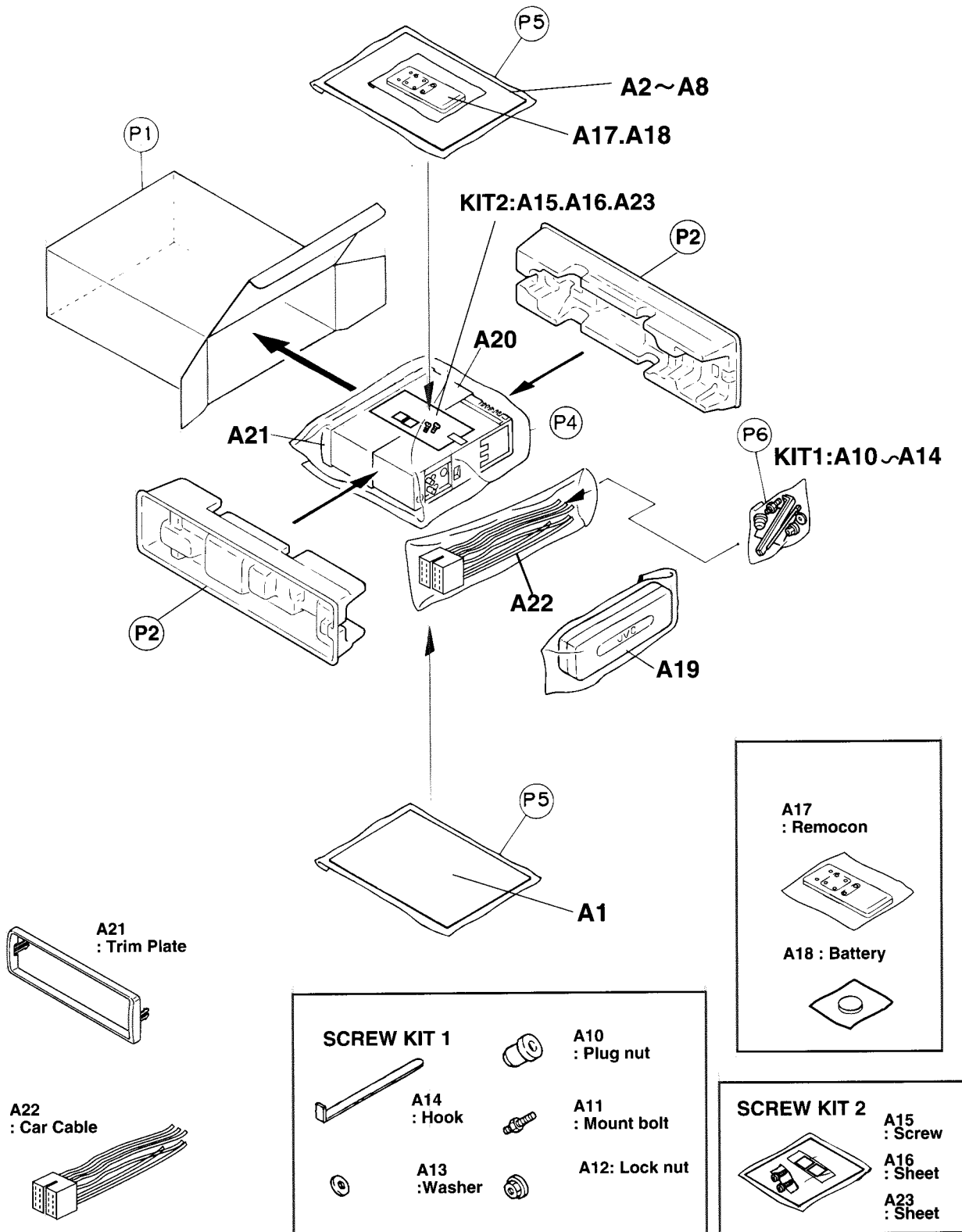

■ Packing parts list

Block No. M3MM

△	Item	Parts number	Parts name	Q'ty	Description	Area
	P 1	FSPE3004-081	PACKING CASE	1		
	P 2	FSPH1014-001	PAPER CUSHION	2		
	P 4	VPE3005-064	POLY BAG	1		
	P 5	QPA01703505P	POLY BAG	2	FOR INST. BOOK	
	P 6	QPA00801205	POLY BAG	1		

■ Accessories parts list

Block No. M4MM

△	Item	Parts number	Parts name	Q'ty	Description	Area
	A 1	FSUN3124-311	INST.BOOK	1	ENG GER FRE DUT	
	A 2	FSUN3124-321	INST.BOOK	1	SPA ITA SWE FIN	
	A 3	FSUN3124-T211	INSTRUCT.SHEET	1	ENG GER FRE	
	A 4	FSUN3124-T451	INSTRUCT.SHEET	1	DUT SPA ITA	
	A 5	FSUN3124-T481	INSTRUCT.SHEET	1	SWE FIN	
	A 6	BT-54013-1	WARRANTY CARD	1		
	A 8	FSYA4003-001	CAUTION SHEET	1		
	A 10	VKZ4027-202	PLUG NUT	1		
	A 11	VKH4871-001SS	MOUNT BOLT	1		
	A 12	VKZ4328-001	LOCK NUT	1		
	A 13	WNS5000Z	WASHER	1		
	A 14	FSKL4010-002	HOOK	2		
	A 15	VKZ4777-001	MINI SCREW	2	THEFT PREVENTIO	
	A 16	FSYA4002-001	SHEET	1	THEFT PREVENTIO	
	A 17	RM-RK25	REMOCON	1		
	A 18	-----	BATTERY	1		
	A 19	FSJB3001-30A	HARD CASE	1		
	A 20	FSKM2004-202	MOUNTING SLEEVE	1		
	A 21	FSJD2034-001	TRIM PLATE	1		
	A 22	QAM0176-001	CAR CABLE	1		
	A 23	FSYH4036-043	SHEET	2		
	KIT 1	KDGS717K-SCREW1	SCREW PARTS KIT	1	A10-A14	
	KIT 2	KDSX959-SCREW2	SCREW PARTS KIT	1	A15 A16 A23	

KS-FX950R

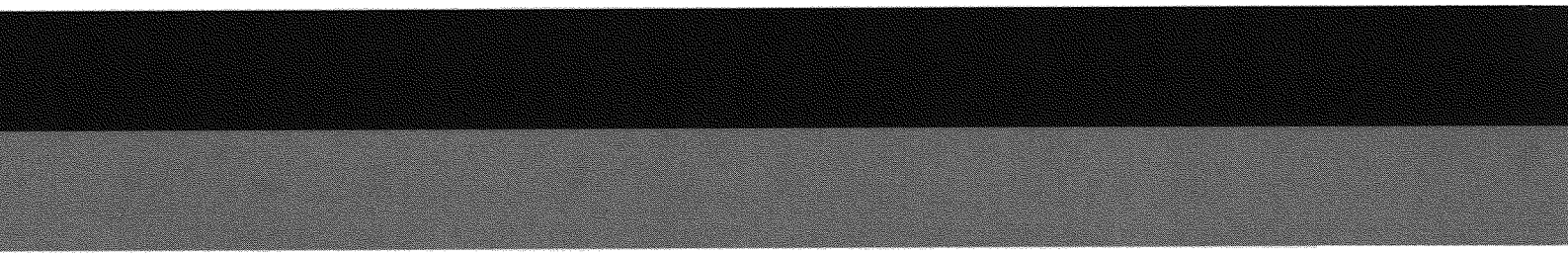

JVC

VICTOR COMPANY OF JAPAN, LIMITED
MOBILE ELECTRONICS DIVISION, 10-1, Chome, Ohwatari-machi, Maebashi-city, Japan

(No.49538)

 Printed in Japan
200002(V)